

2004 SYSTEM WIRING DIAGRAMS

BMW - X5

USING MITCHELL1'S WIRING DIAGRAMS

For information on using these wiring diagrams, see [USING MITCHELL1'S SYSTEM WIRING DIAGRAMS](#) article.

AIR CONDITIONING

2004 BMW X5 30i

2004 SYSTEM WIRING DIAGRAMS BMW - X5

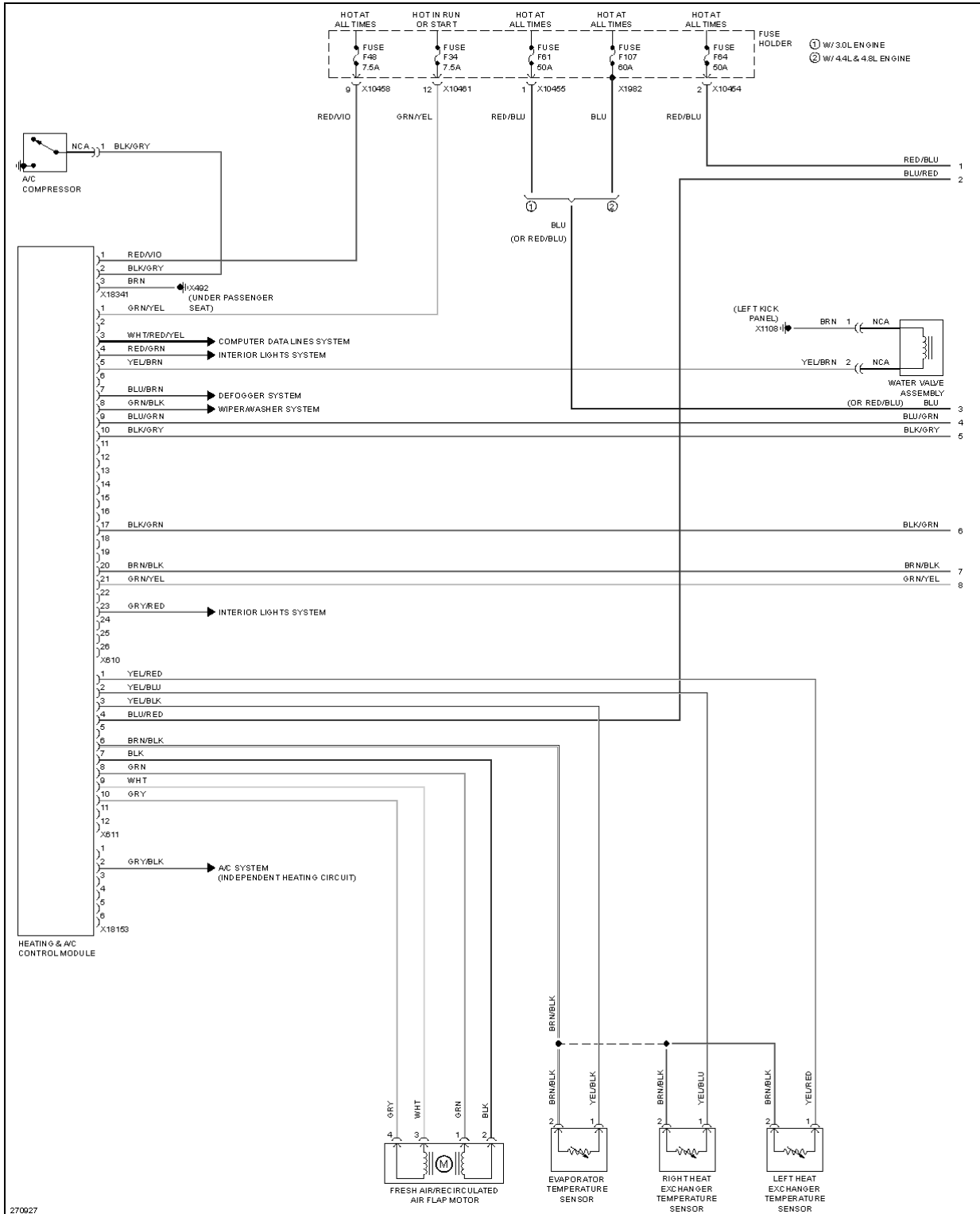

Fig. 1: Automatic A/C Circuit, Basic A/C (1 of 2)

2004 BMW X5 30i

2004 SYSTEM WIRING DIAGRAMS BMW - X5

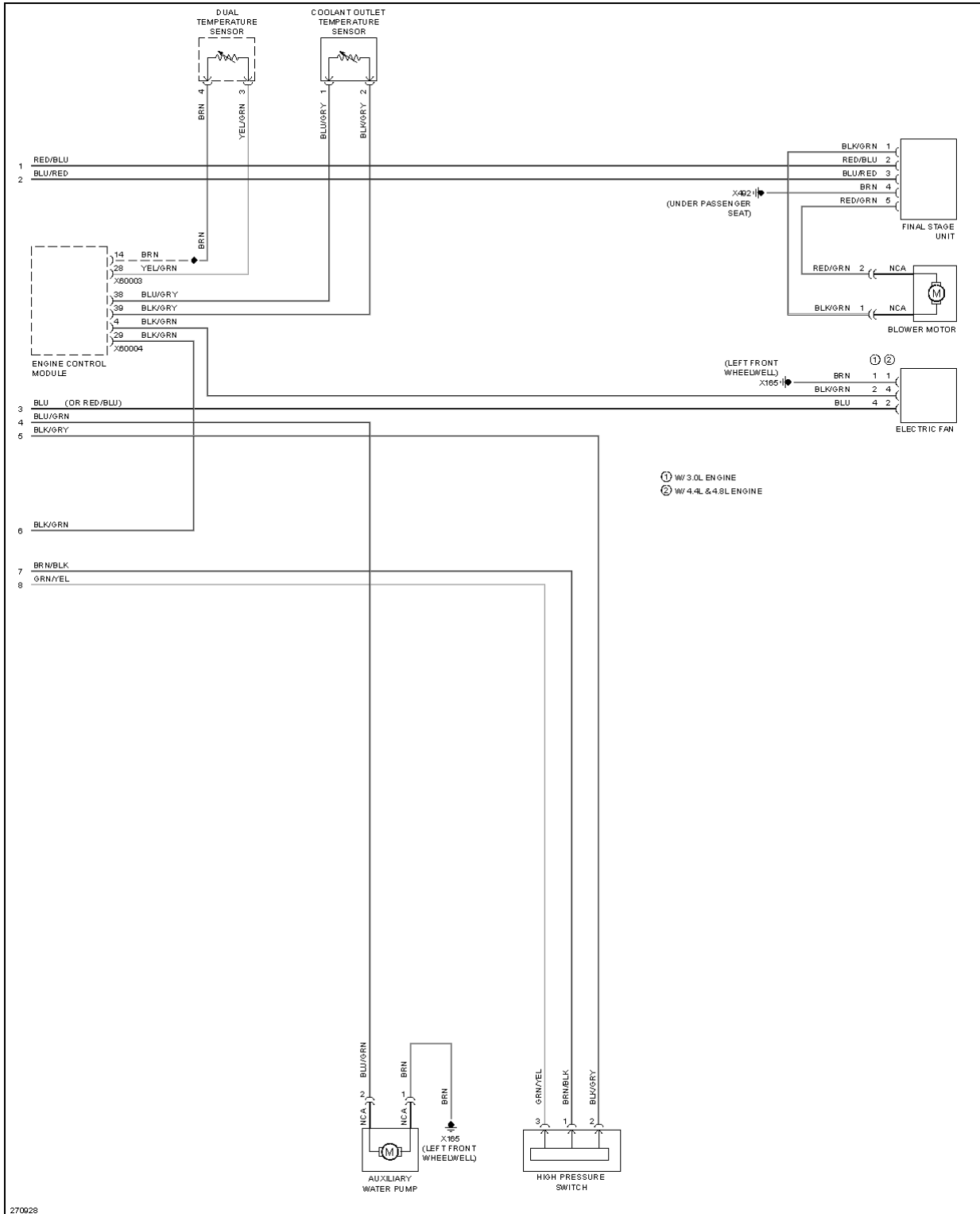

Fig. 2: Automatic A/C Circuit, Basic A/C (2 of 2)

2004 BMW X5 30i

2004 SYSTEM WIRING DIAGRAMS BMW - X5

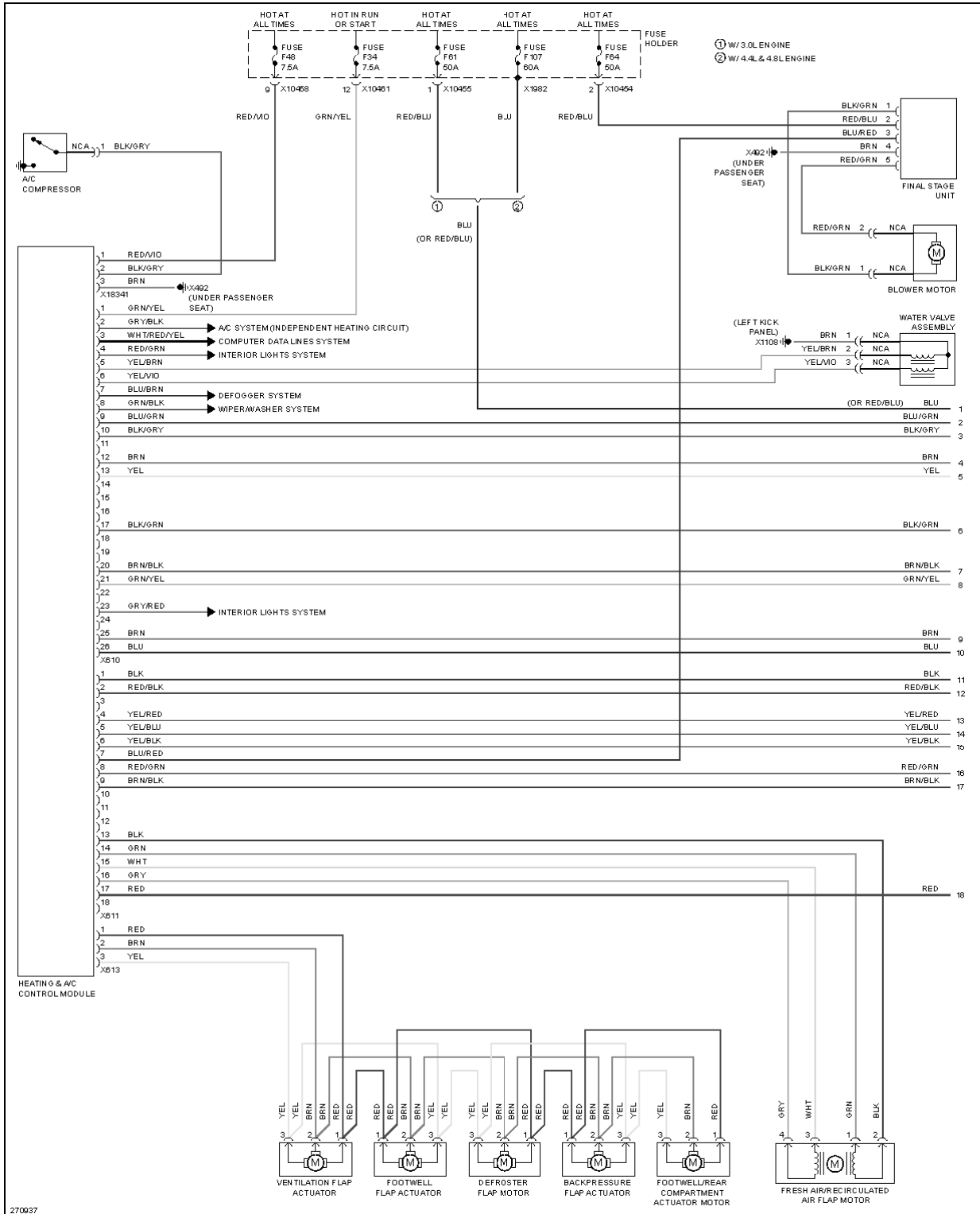

Fig. 3: Automatic A/C Circuit, High A/C, W/ Rear Compartment Blower (1 of 2)

2004 BMW X5 30i

2004 SYSTEM WIRING DIAGRAMS BMW - X5

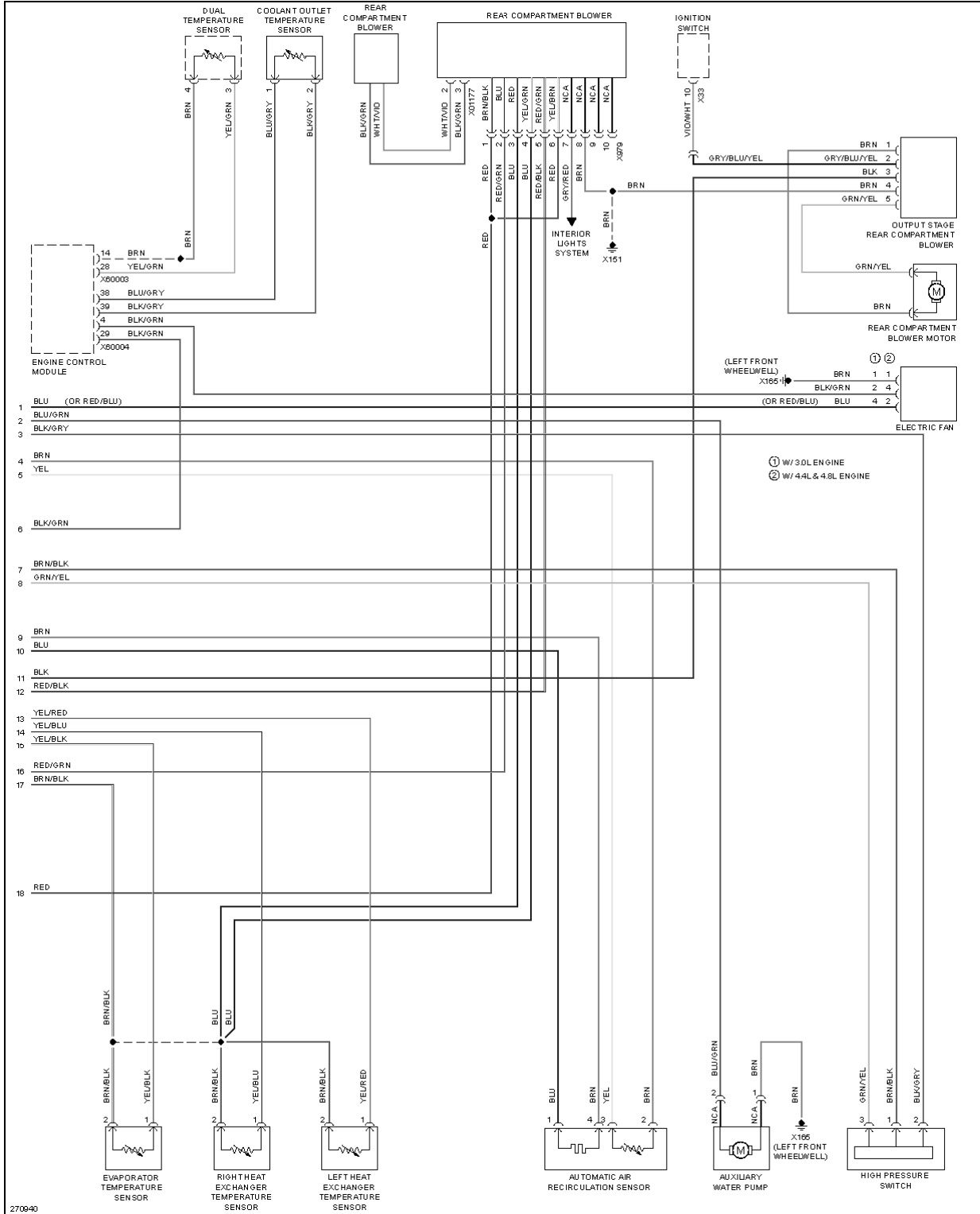

Fig. 4: Automatic A/C Circuit, High A/C, W/ Rear Compartment Blower (2 of 2)

2004 BMW X5 30i

2004 SYSTEM WIRING DIAGRAMS BMW - X5

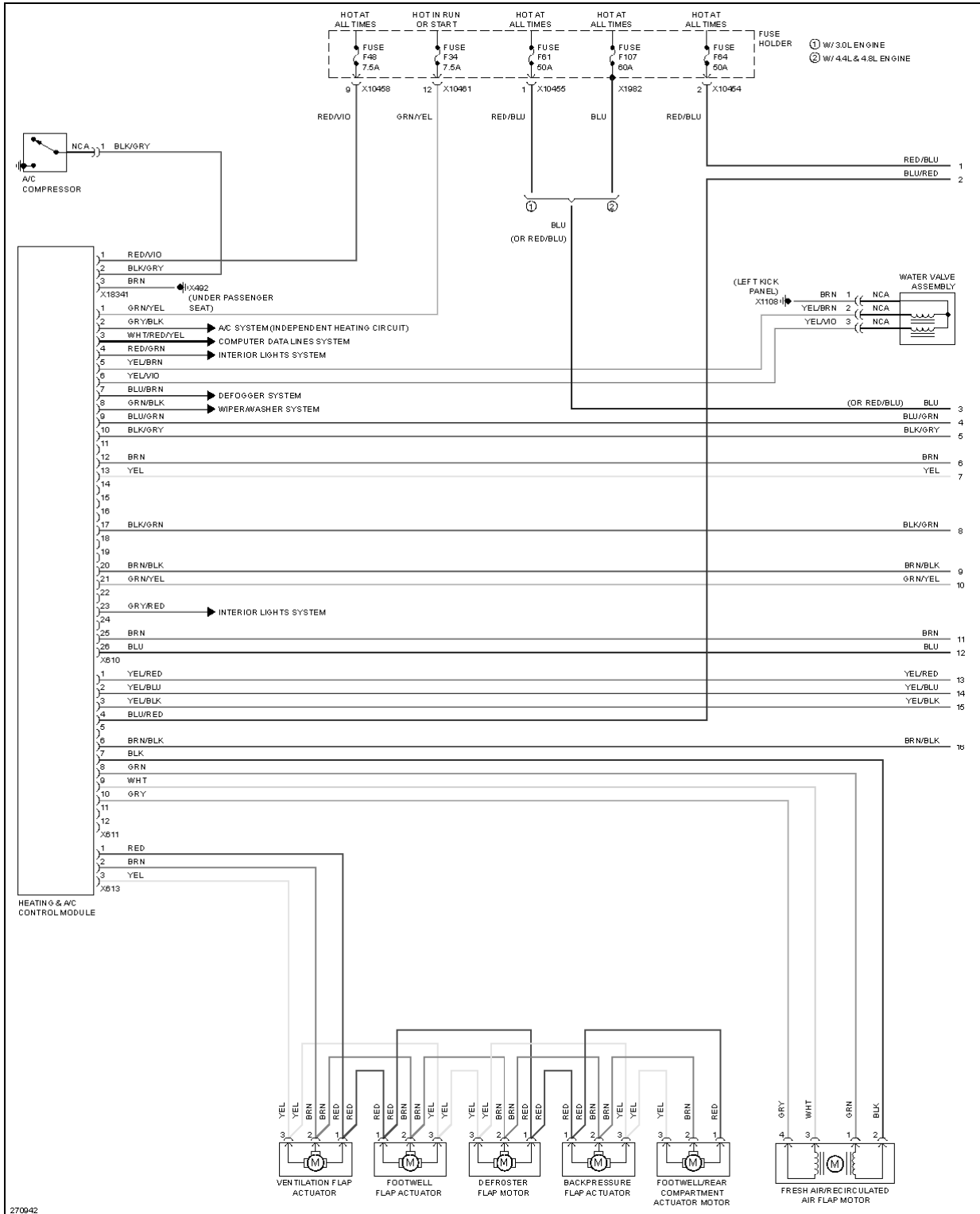

Fig. 5: Automatic A/C Circuit, High A/C, W/O Rear Compartment Blower (1 of 2)

2004 BMW X5 30i

2004 SYSTEM WIRING DIAGRAMS BMW - X5

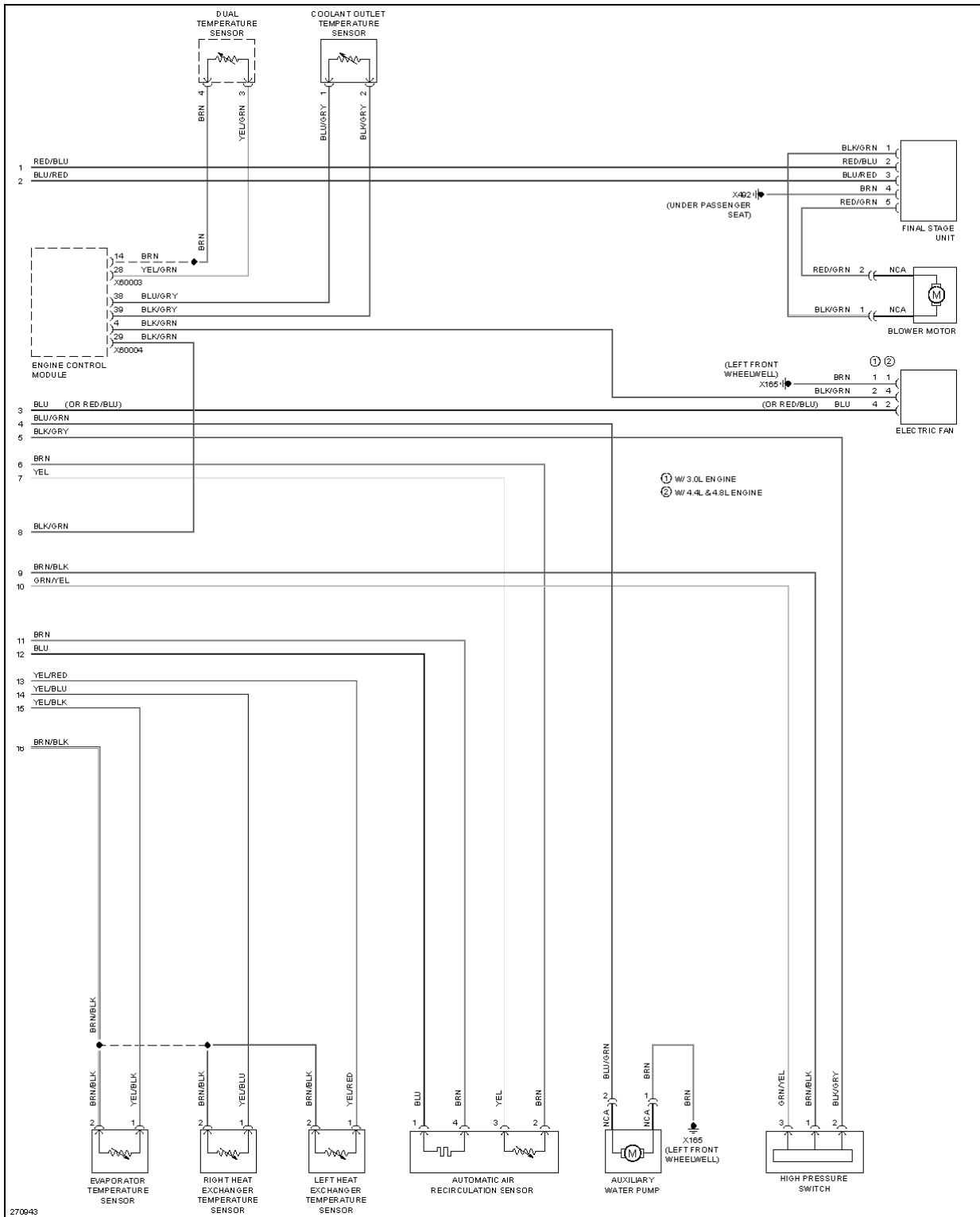

Fig. 6: Automatic A/C Circuit, High A/C, W/O Rear Compartment Blower (2 of 2)

2004 BMW X5 30i

2004 SYSTEM WIRING DIAGRAMS BMW - X5

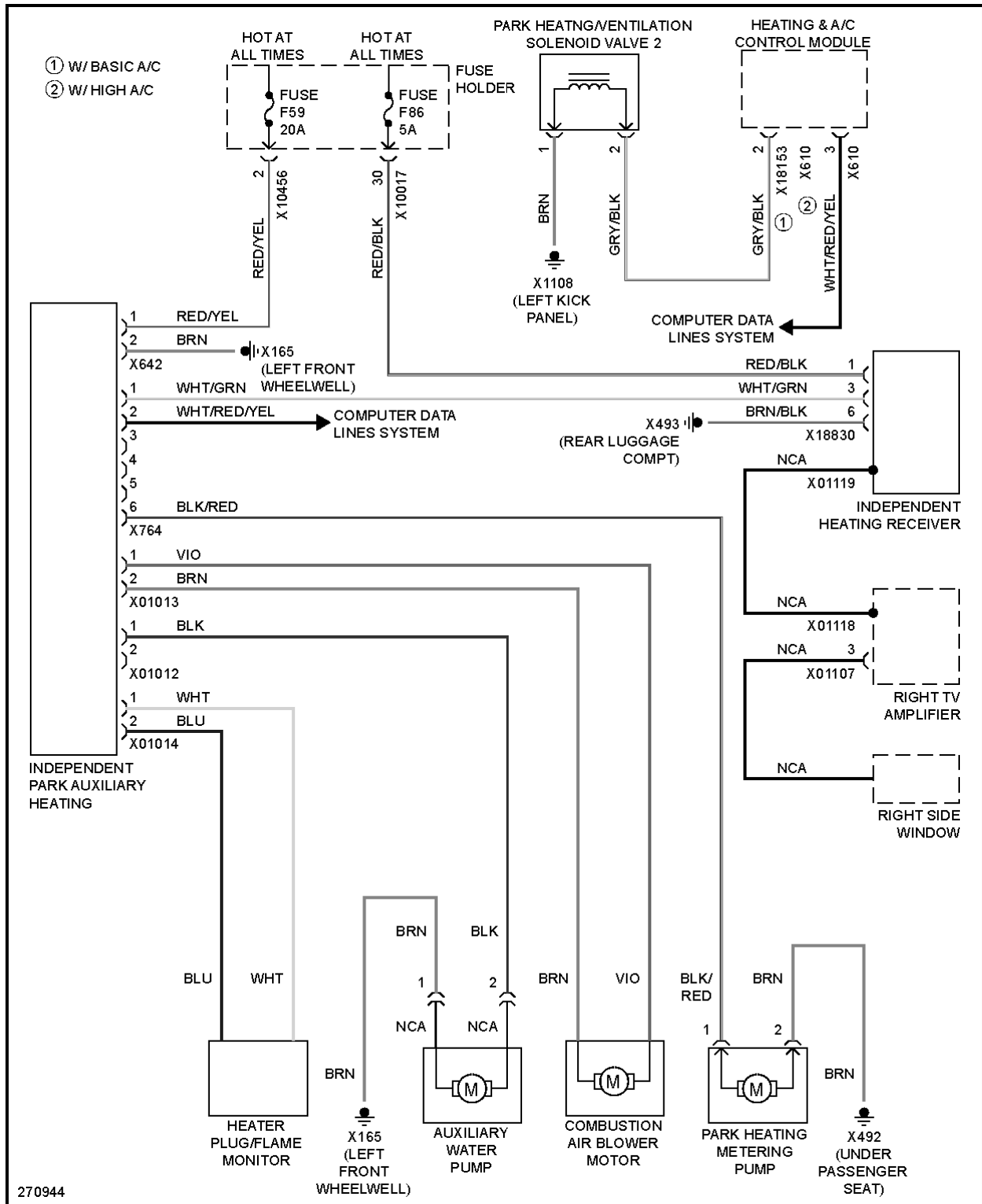

Fig. 7: Independent Heating Circuit

ANTI-LOCK BRAKES

2004 BMW X5 30i

2004 SYSTEM WIRING DIAGRAMS BMW - X5

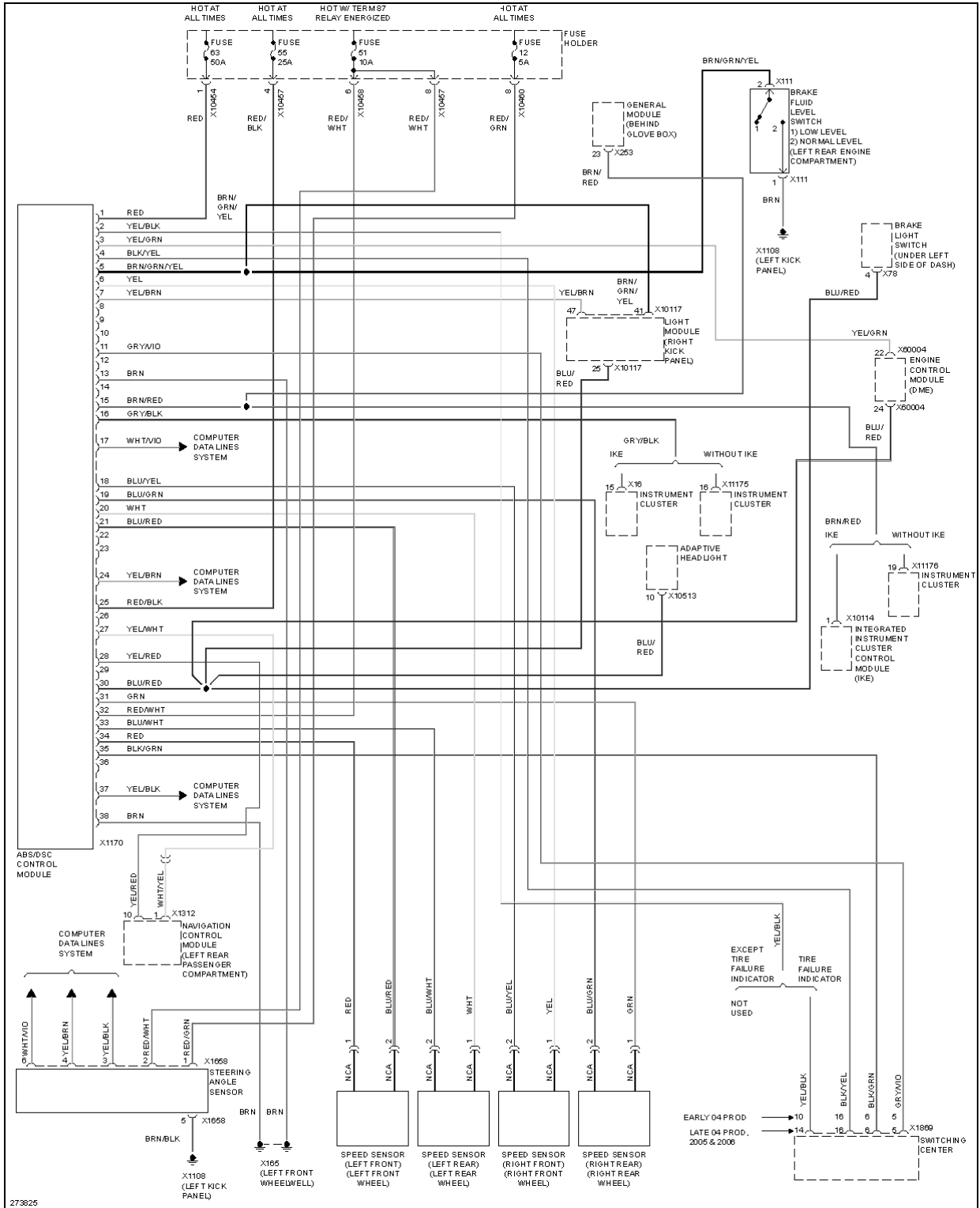

Fig. 8: Anti-lock Brakes Circuit

ANTI-THEFT

2004 BMW X5 30i

2004 SYSTEM WIRING DIAGRAMS BMW - X5

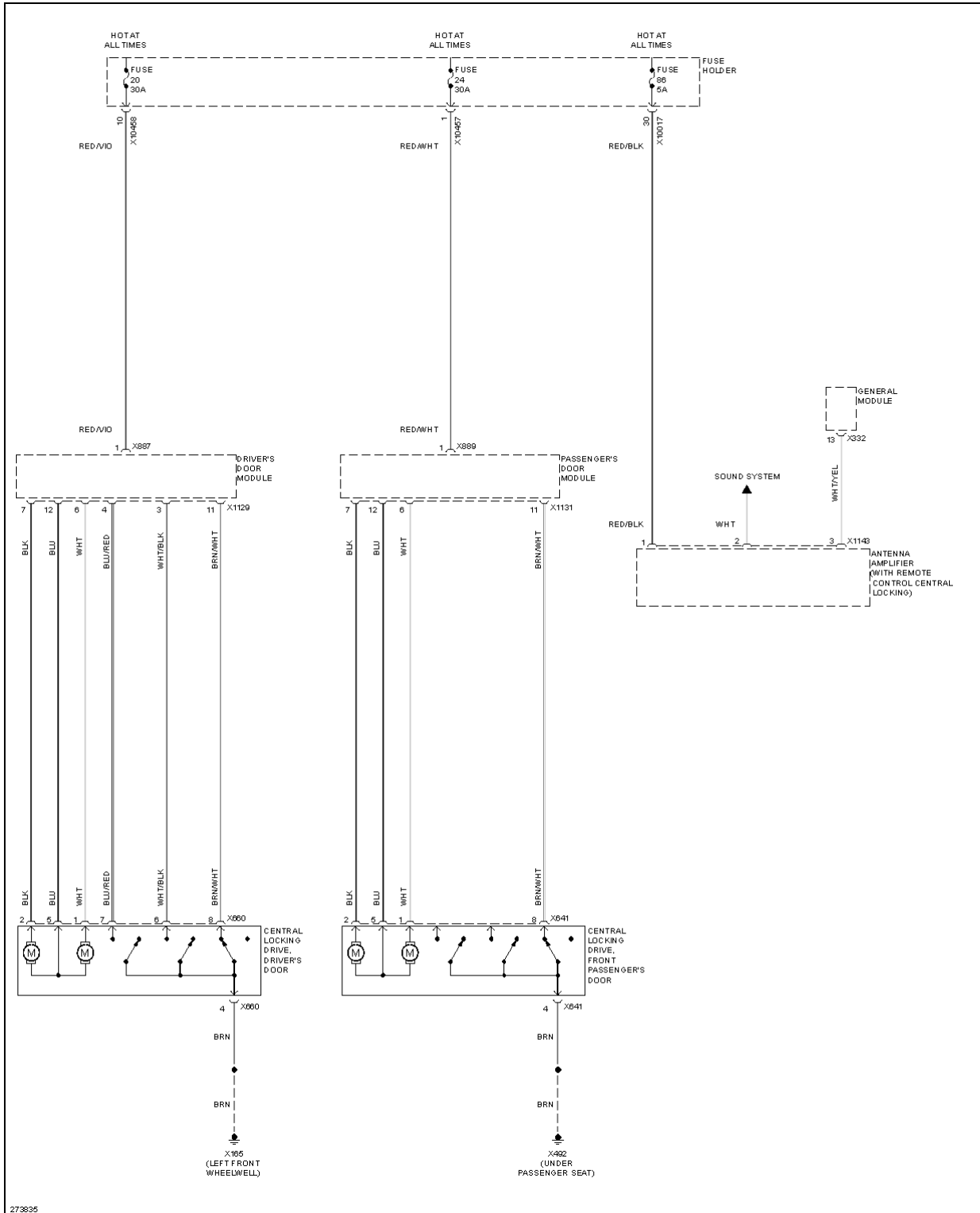

Fig. 9: Anti-theft & Central Locking Circuit (1 of 3)

2004 BMW X5 30i

2004 SYSTEM WIRING DIAGRAMS BMW - X5

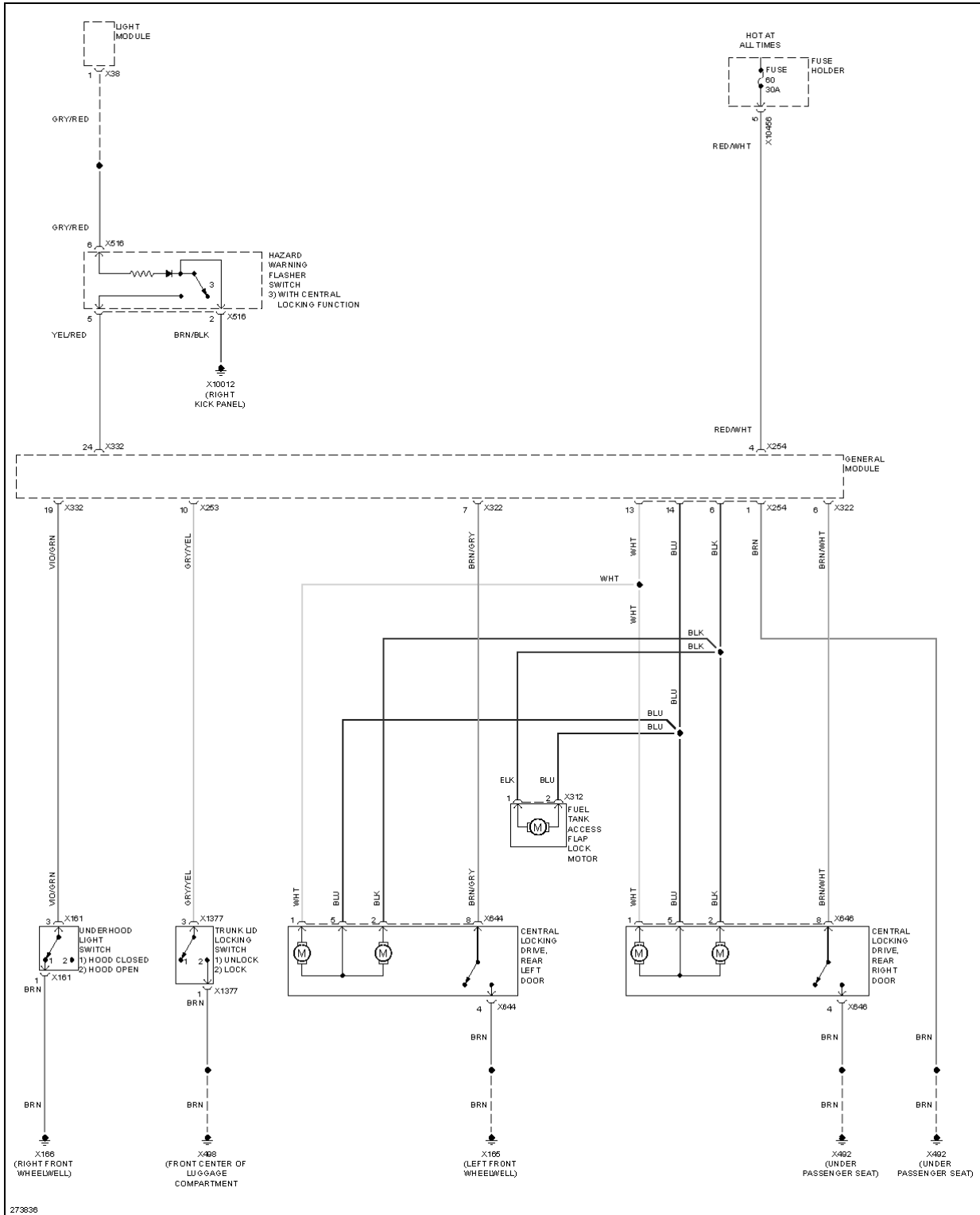

Fig. 10: Anti-theft & Central Locking Circuit (2 of 3)

2004 BMW X5 30i

2004 SYSTEM WIRING DIAGRAMS BMW - X5

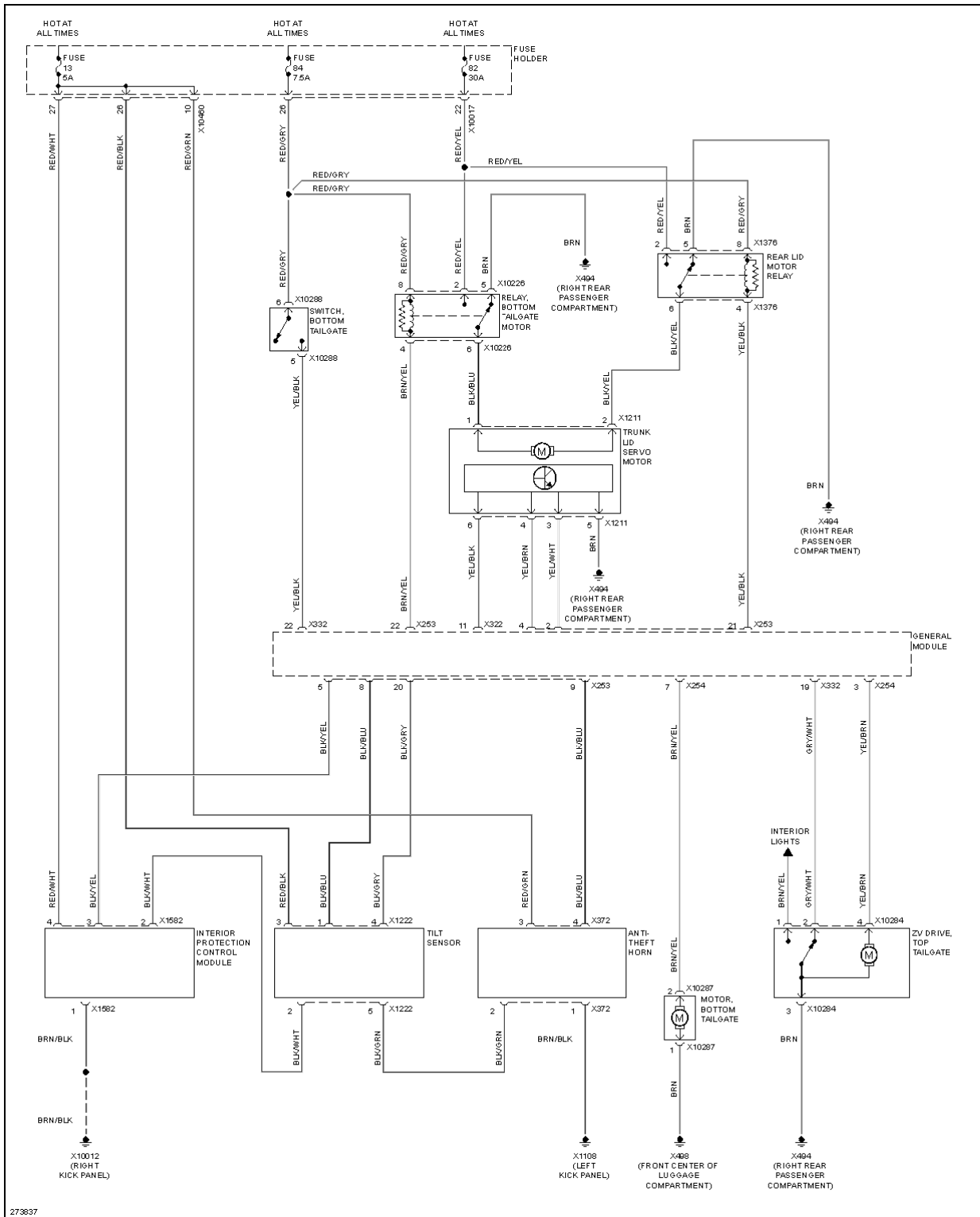

Fig. 11: Anti-theft & Central Locking Circuit (3 of 3)

3.0L

2004 BMW X5 30i

2004 SYSTEM WIRING DIAGRAMS BMW - X5

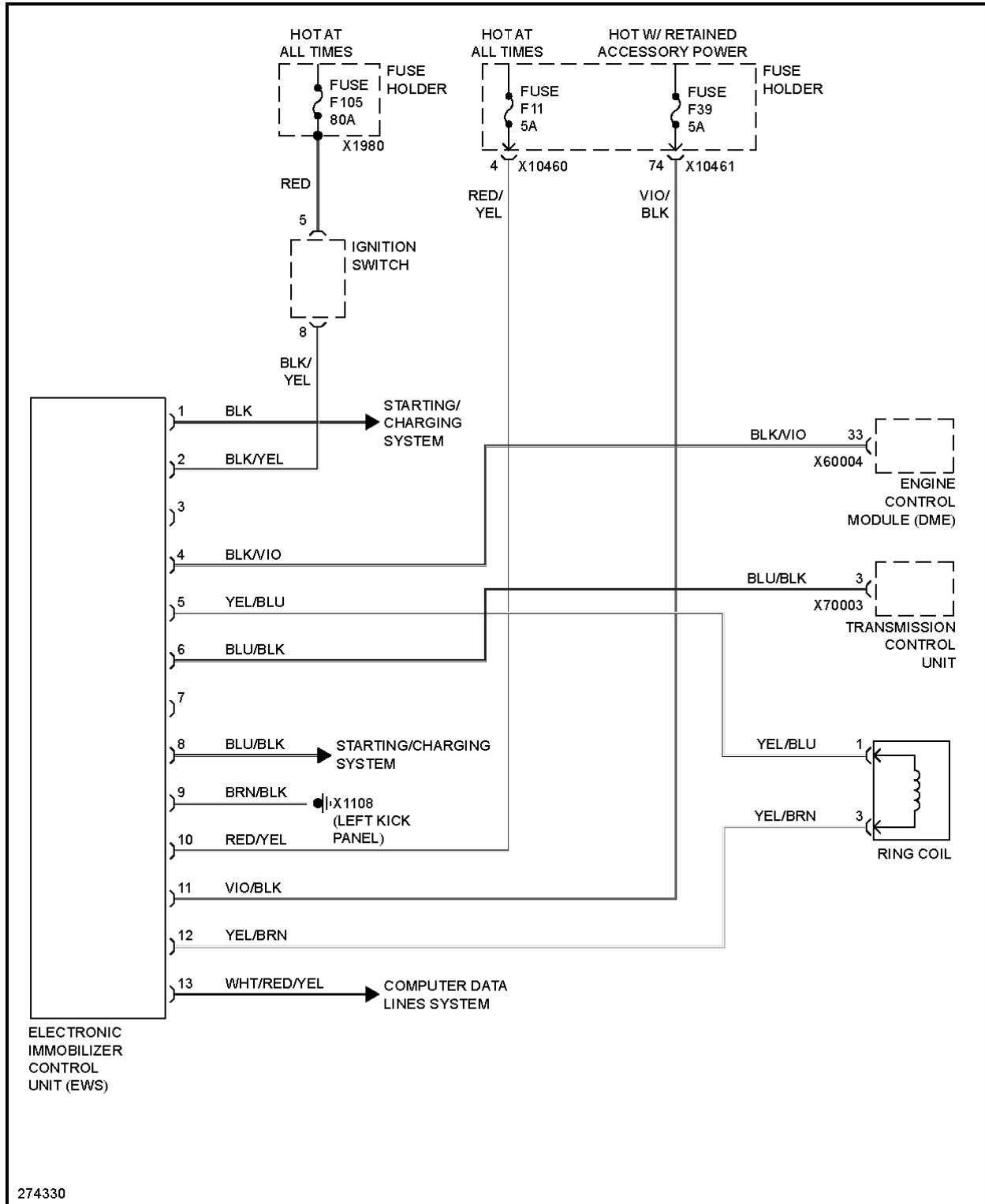

Fig. 12: 3.0L, Immobilizer Circuit

4.4L

2004 BMW X5 30i

2004 SYSTEM WIRING DIAGRAMS BMW - X5

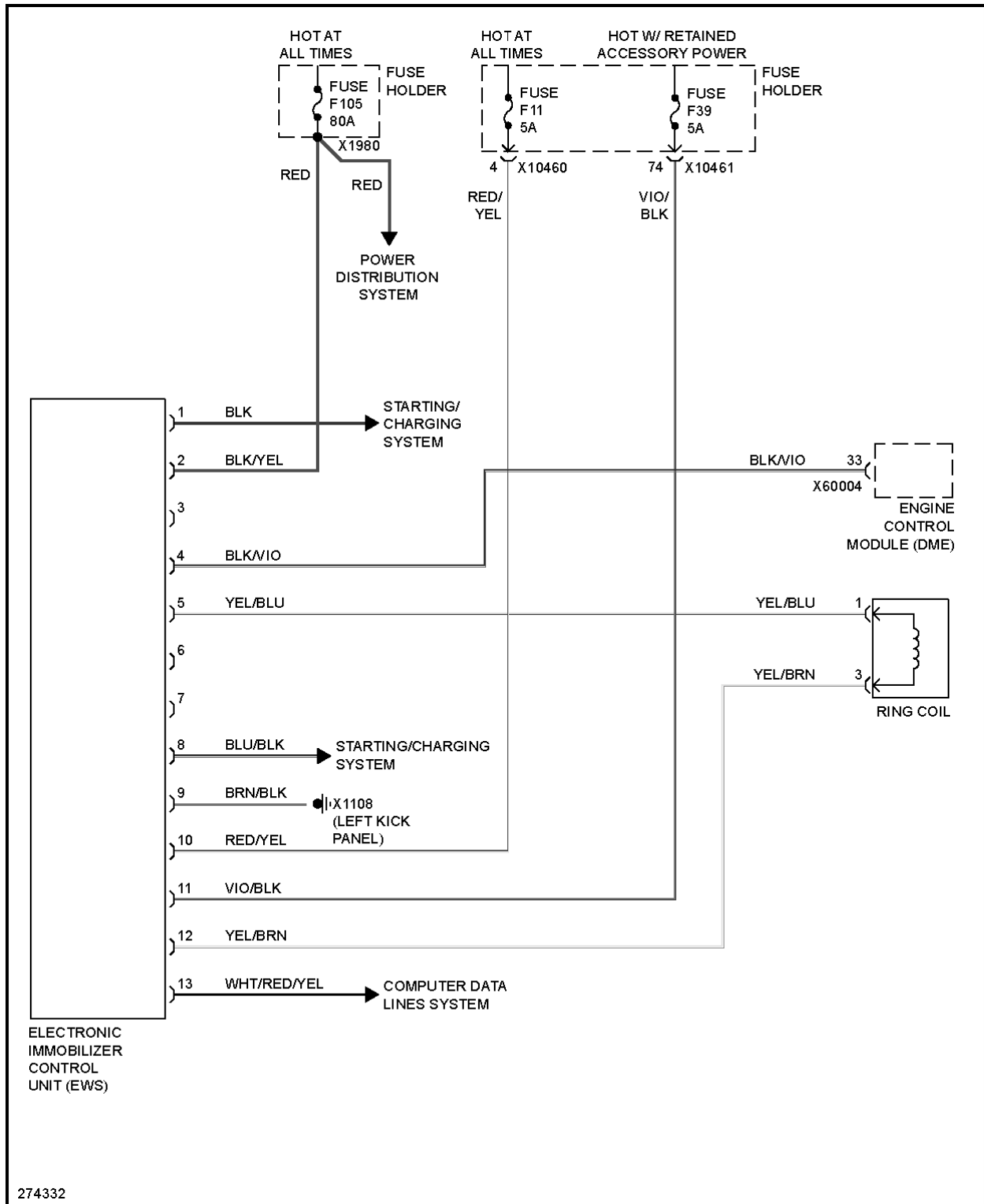

Fig. 13: 4.4L, Immobilizer Circuit

4.8L

2004 BMW X5 30i

2004 SYSTEM WIRING DIAGRAMS BMW - X5

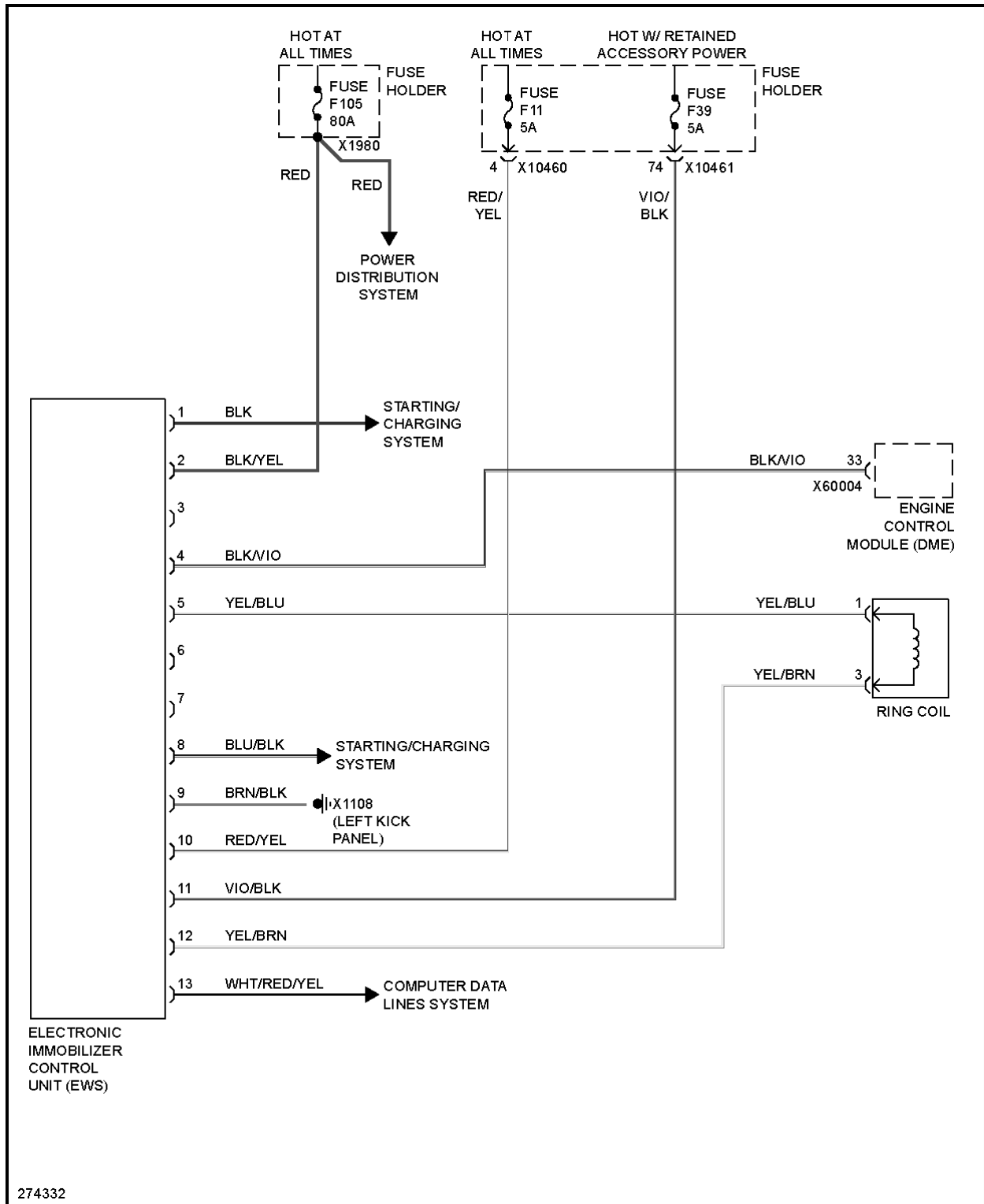

Fig. 14: 4.8L, Immobilizer Circuit

BODY CONTROL MODULES

2004 BMW X5 30i

2004 SYSTEM WIRING DIAGRAMS BMW - X5

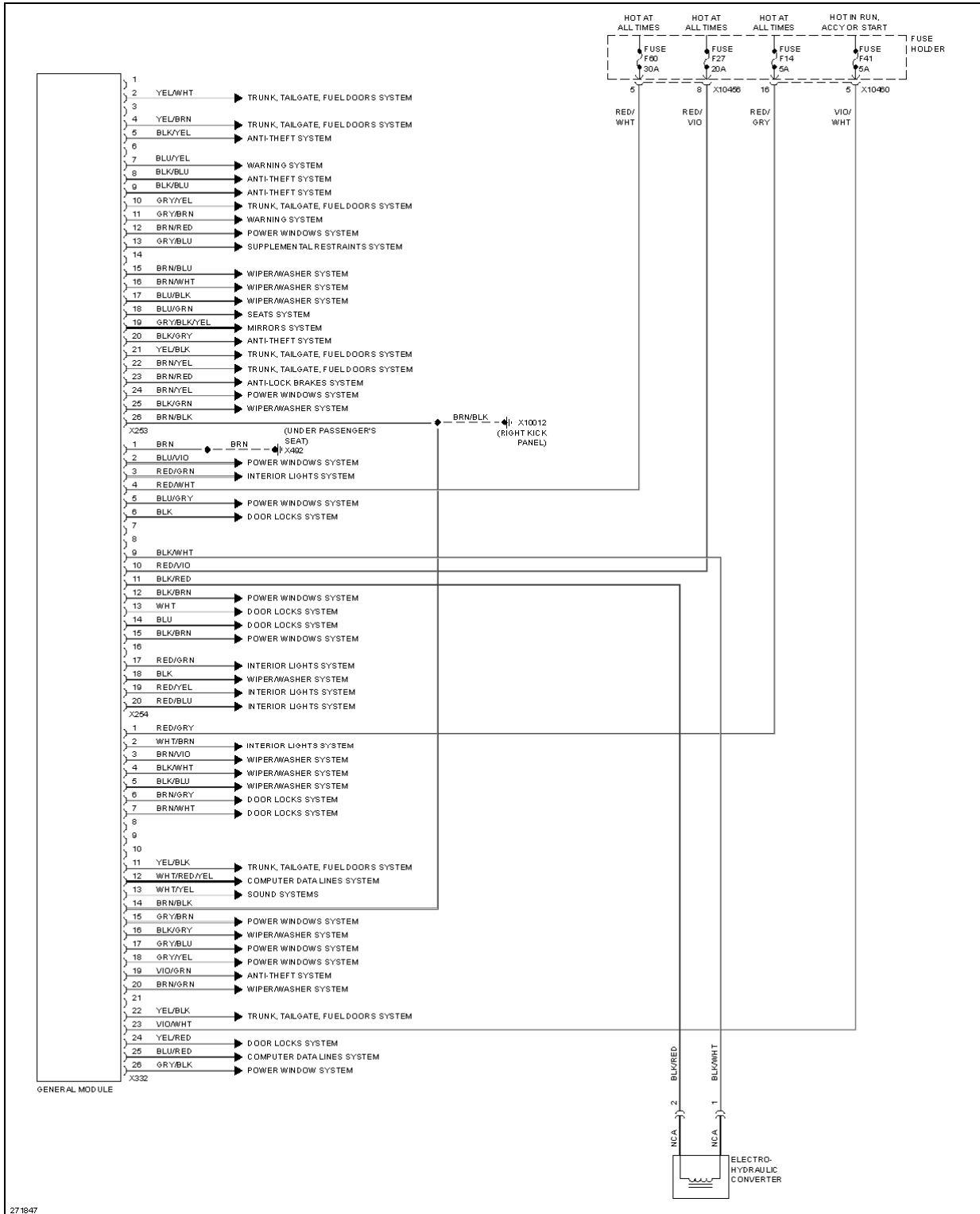

Fig. 15: Body Control Modules Circuit

COMPUTER DATA LINES

3.0L

2004 BMW X5 30i

2004 SYSTEM WIRING DIAGRAMS BMW - X5

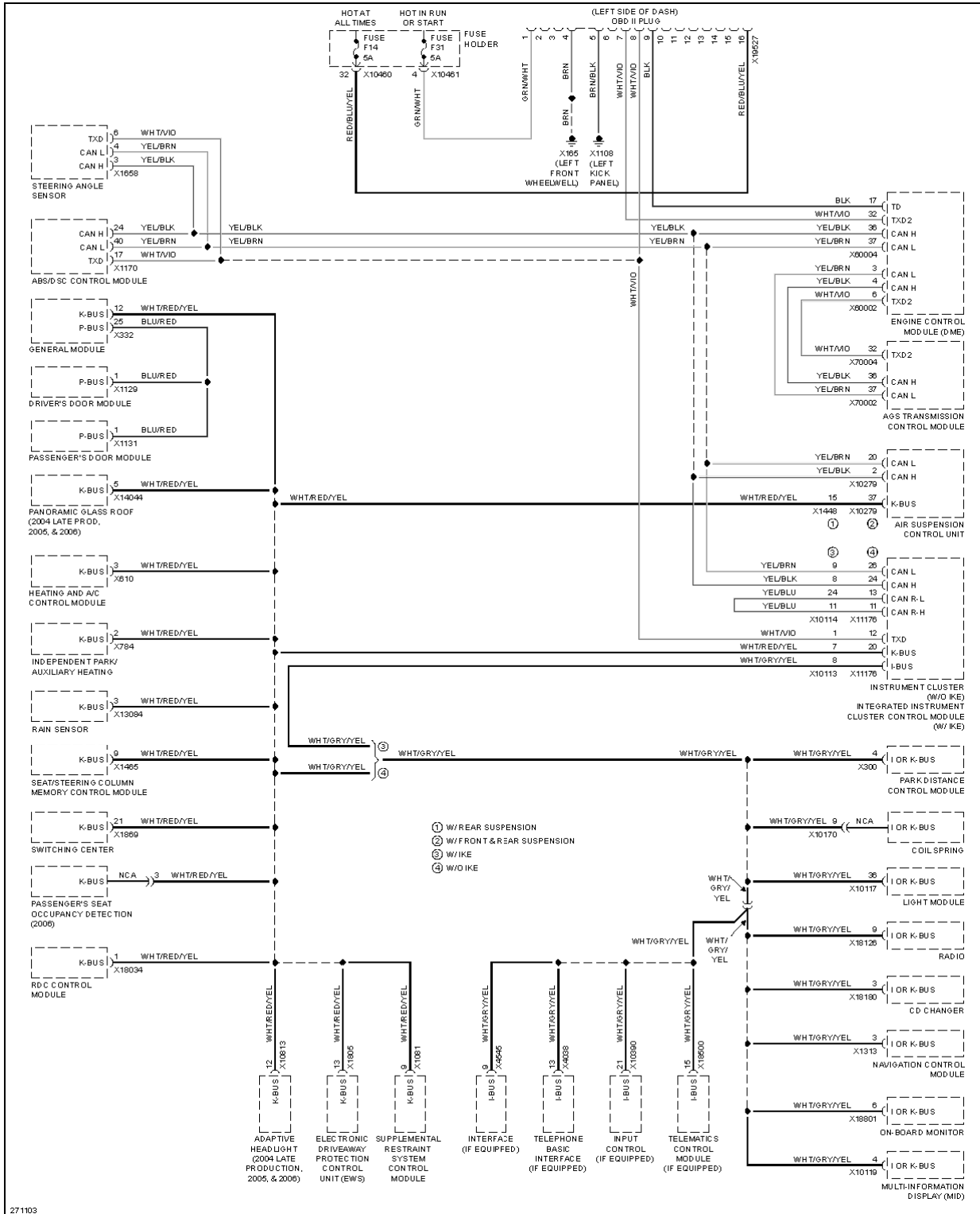

Fig. 16: 3.0L, Computer Data Lines Circuit

4.4L

2004 BMW X5 30i

2004 SYSTEM WIRING DIAGRAMS BMW - X5

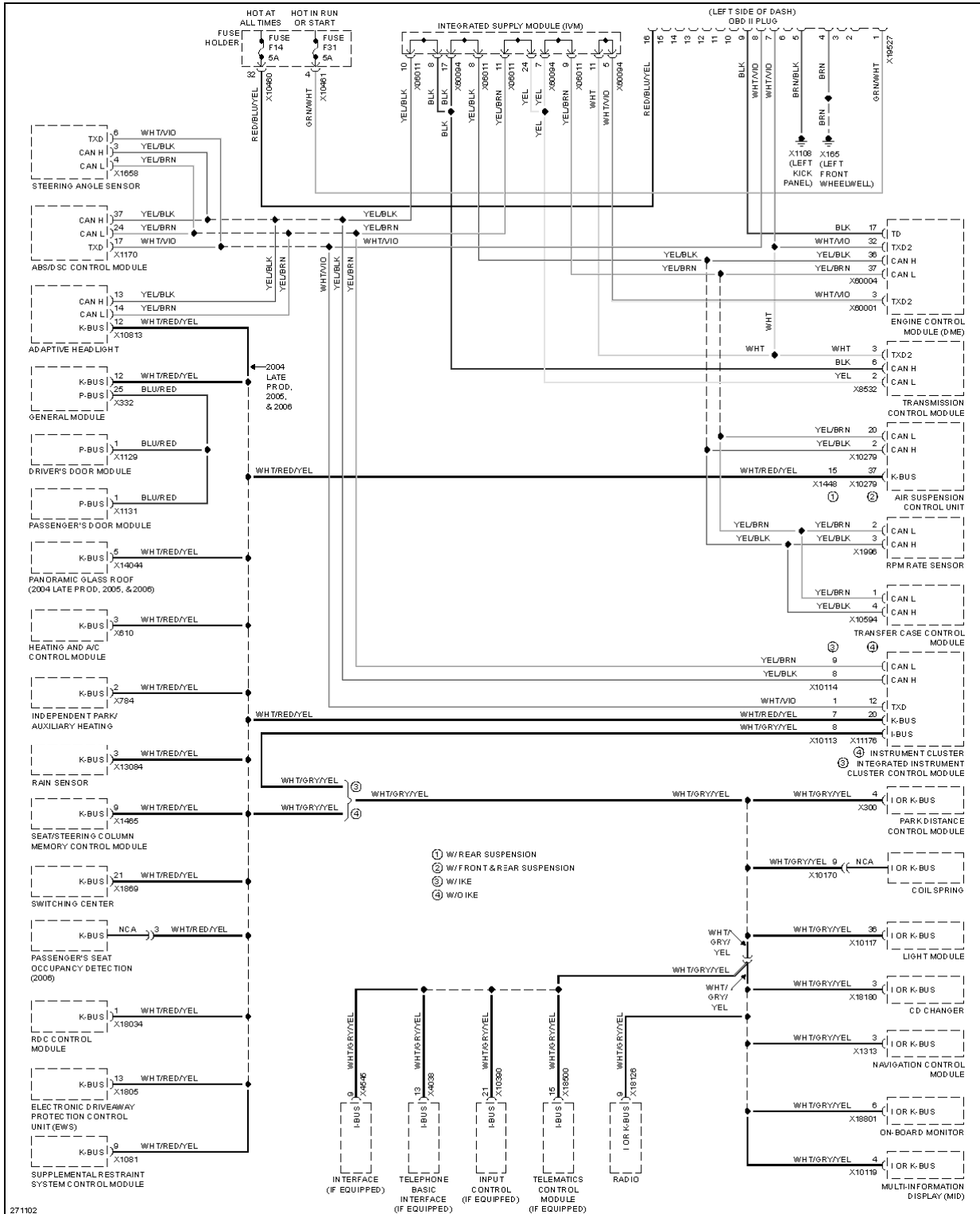

Fig. 17: 4.4L, Computer Data Lines Circuit

4.8L

2004 BMW X5 30i

2004 SYSTEM WIRING DIAGRAMS BMW - X5

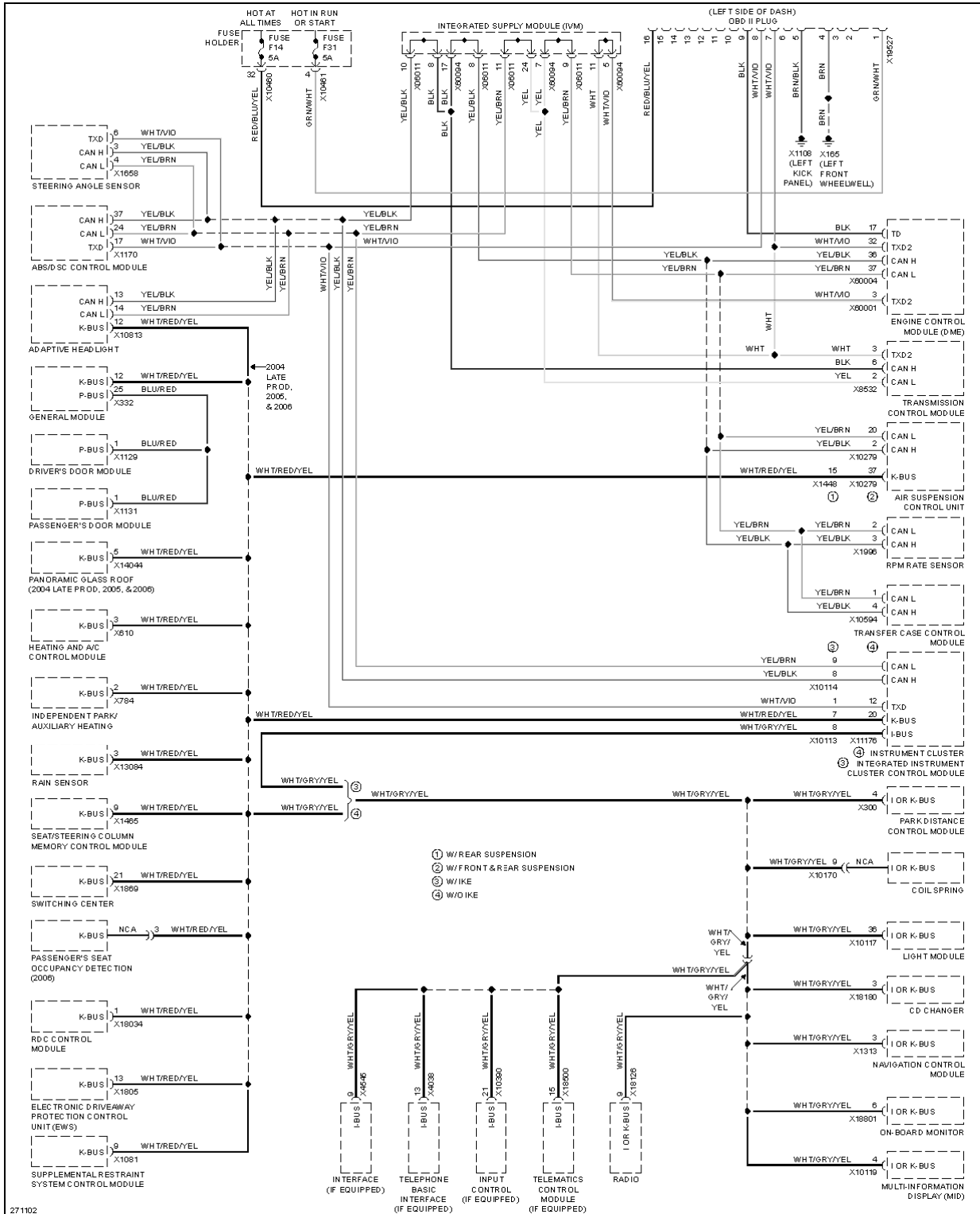

Fig. 18: 4.8L, Computer Data Lines Circuit

COOLING FAN

3.0L

2004 BMW X5 30i

2004 SYSTEM WIRING DIAGRAMS BMW - X5

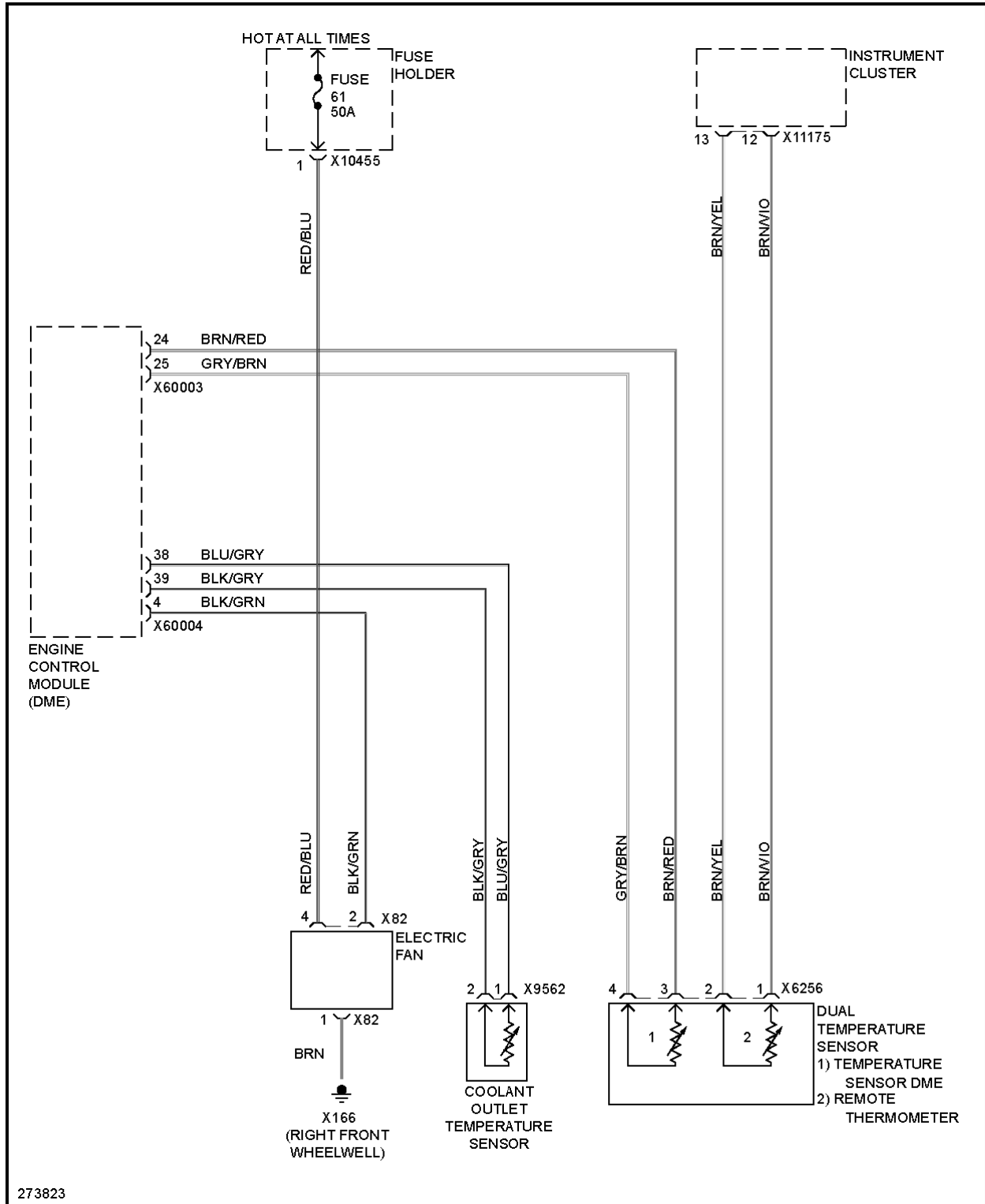

Fig. 19: 3.0L, Cooling Fan Circuit

4.4L

2004 BMW X5 30i

2004 SYSTEM WIRING DIAGRAMS BMW - X5

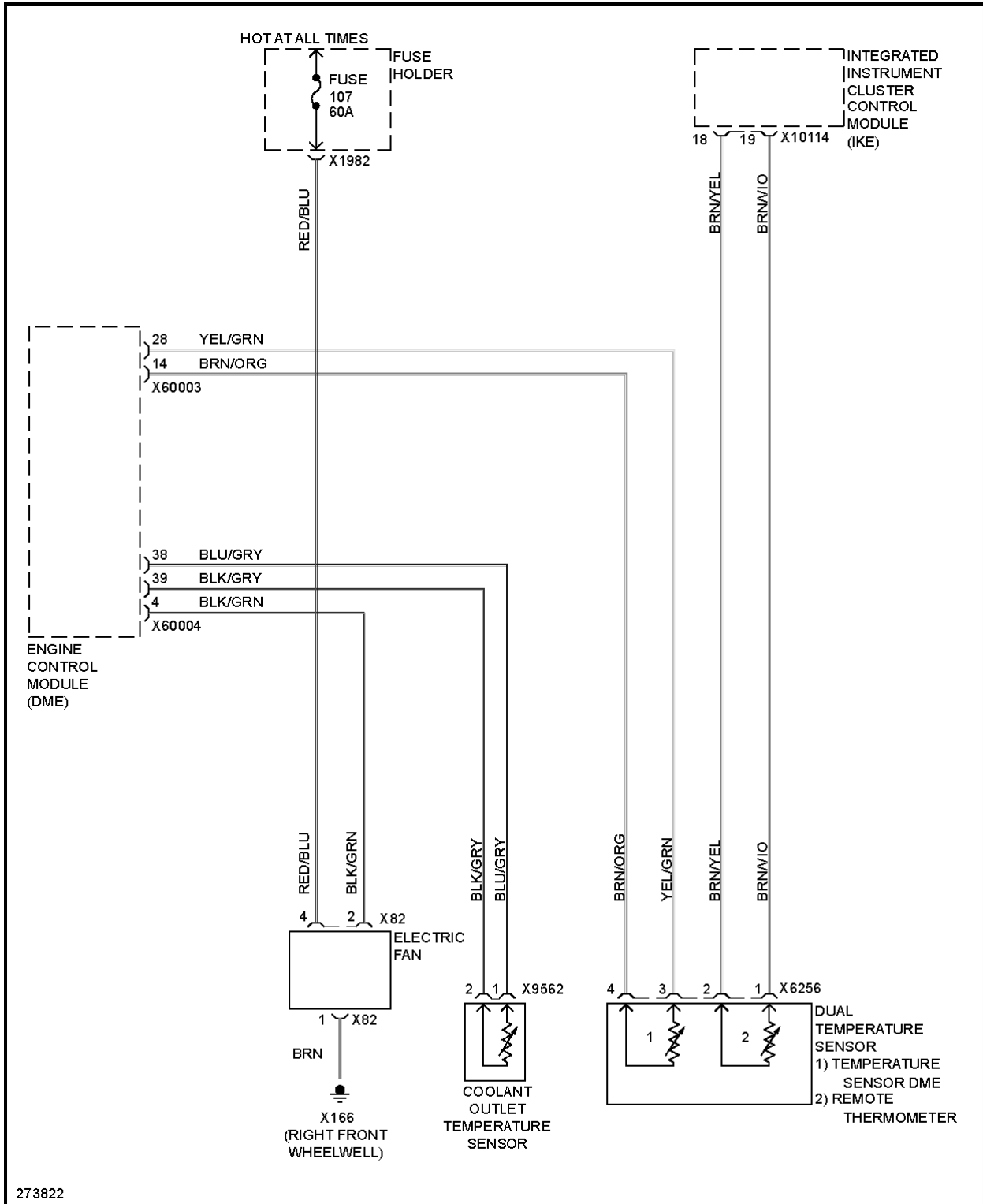

Fig. 20: 4.4L, Cooling Fan Circuit

4.8L

2004 BMW X5 30i

2004 SYSTEM WIRING DIAGRAMS BMW - X5

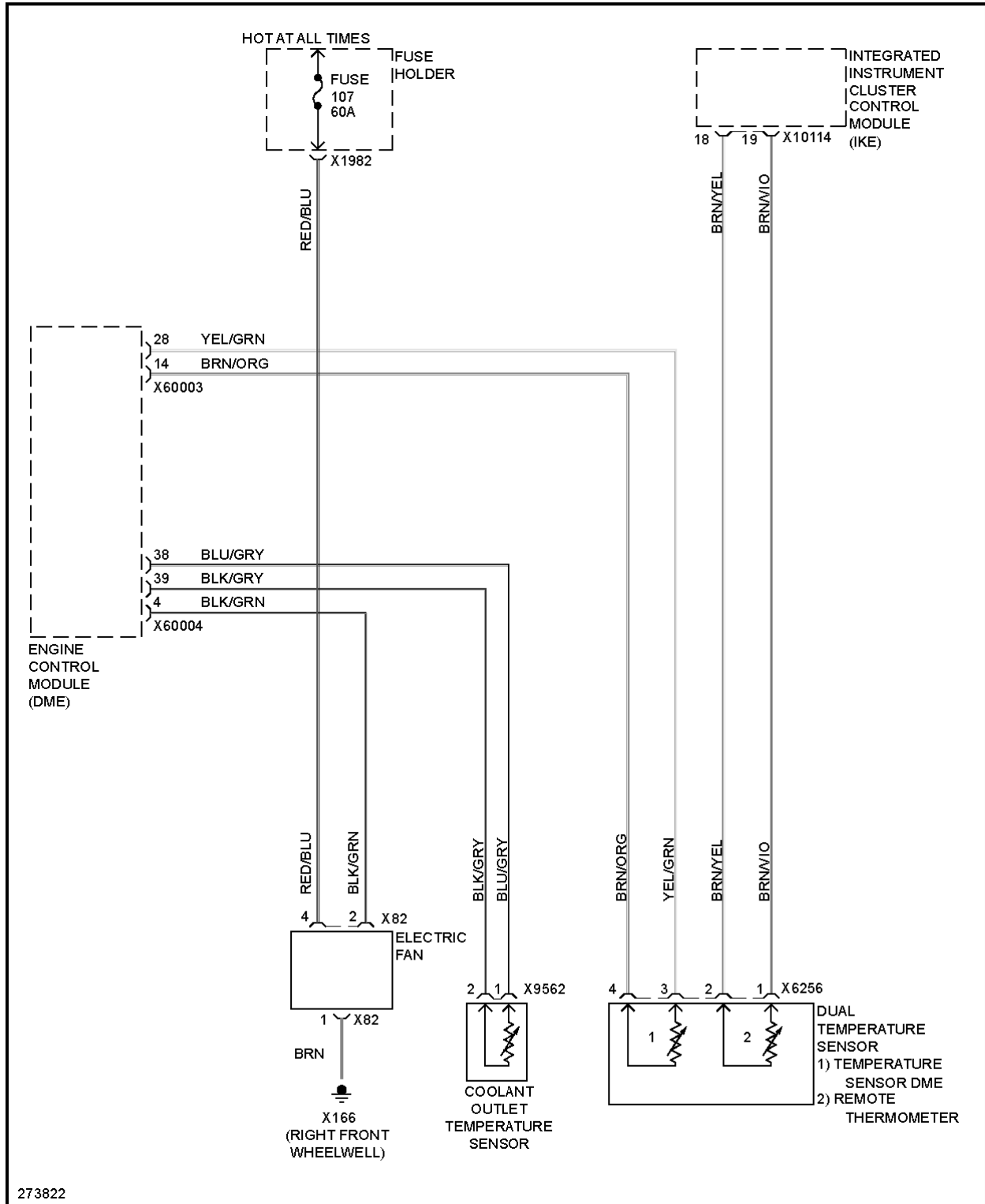

Fig. 21: 4.8L, Cooling Fan Circuit

CRUISE CONTROL

3.0L

2004 BMW X5 30i

2004 SYSTEM WIRING DIAGRAMS BMW - X5

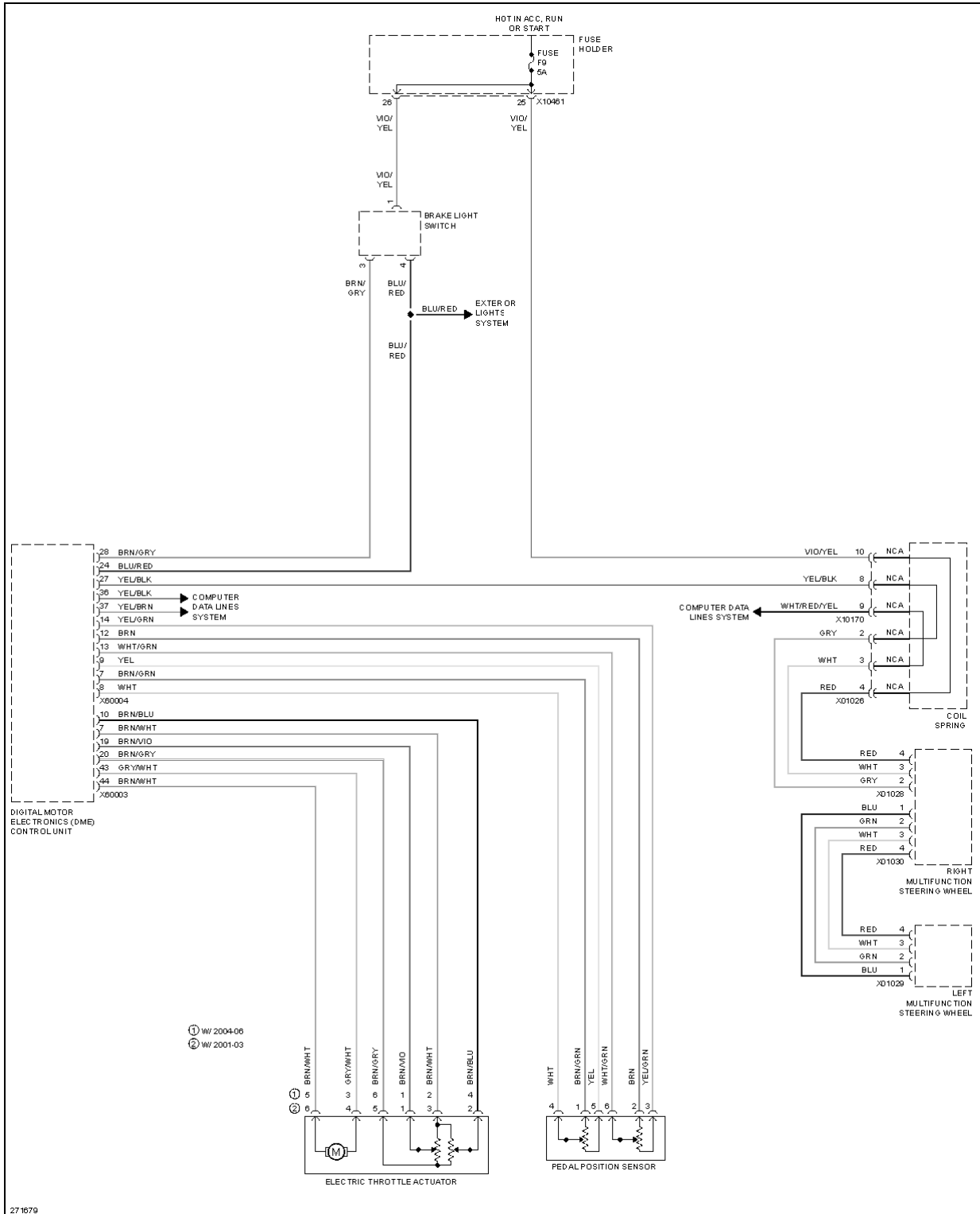

Fig. 22: 3.0L, Cruise Control Circuit

4.4L

2004 BMW X5 30i

2004 SYSTEM WIRING DIAGRAMS BMW - X5

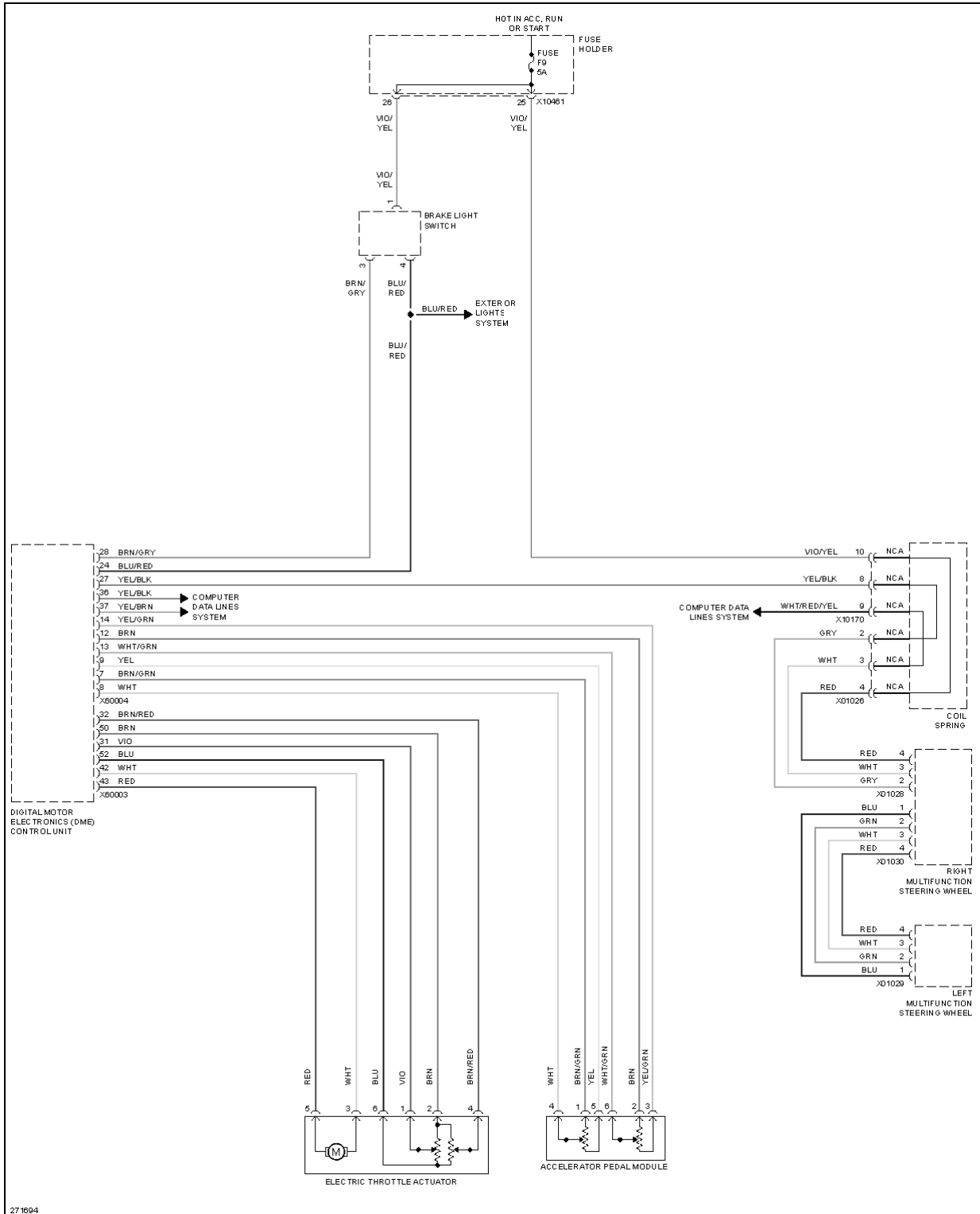

Fig. 23: 4.4L, Cruise Control Circuit

4.8L

2004 BMW X5 30i

2004 SYSTEM WIRING DIAGRAMS BMW - X5

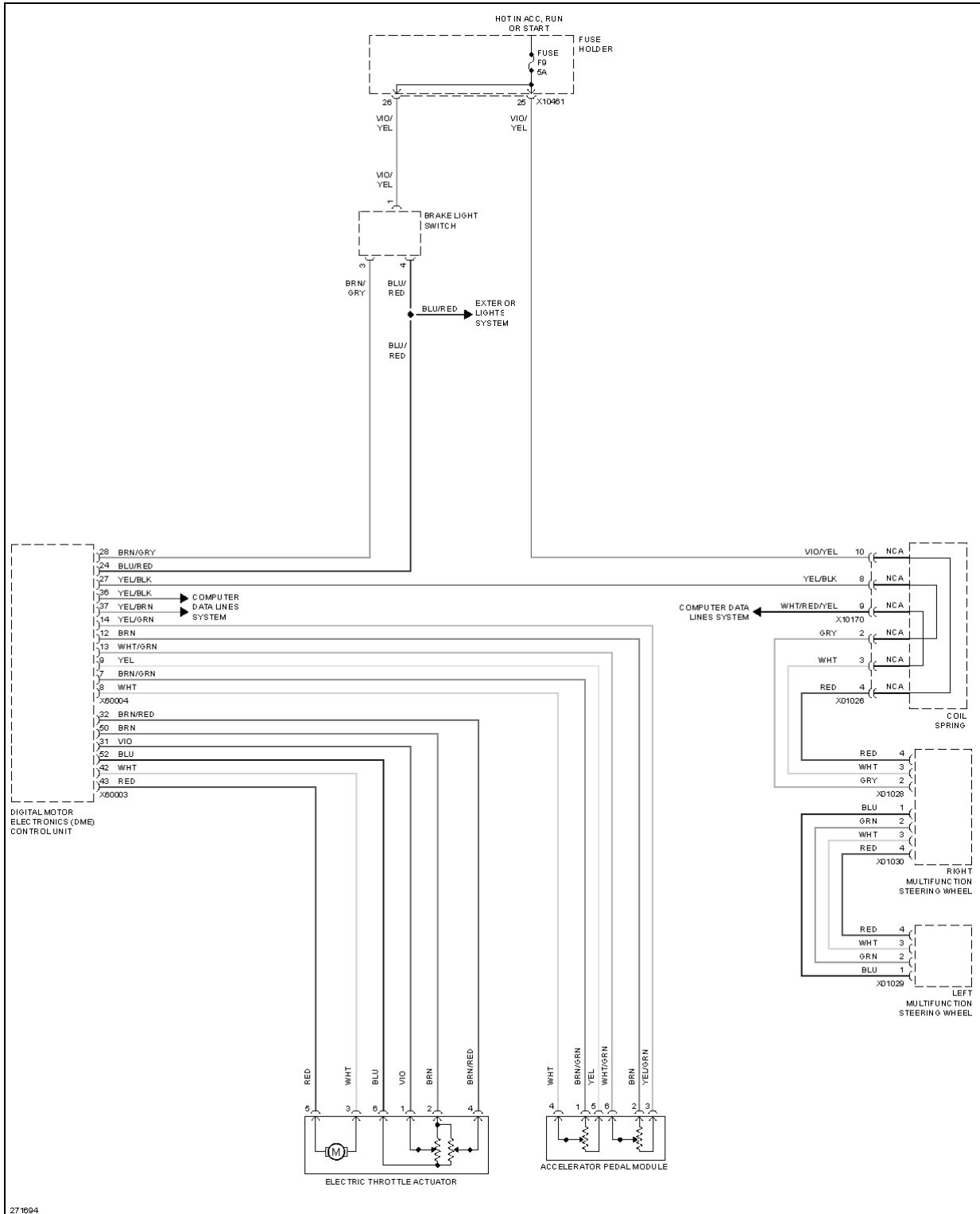

Fig. 24: 4.8L, Cruise Control Circuit

DEFOGGERS

2004 BMW X5 30i

2004 SYSTEM WIRING DIAGRAMS BMW - X5

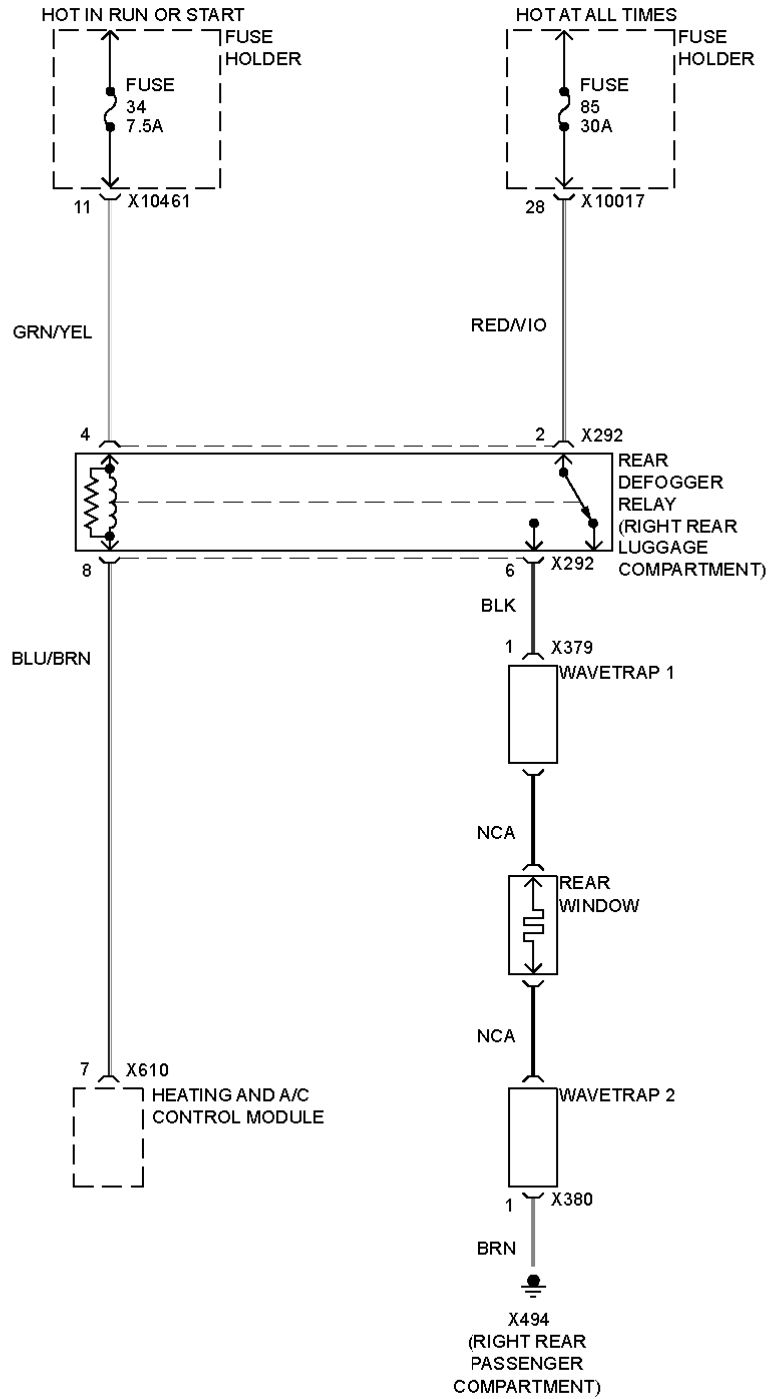

Fig. 25: Rear Defogger Circuit

ELECTRONIC SUSPENSION

2004 BMW X5 30i

2004 SYSTEM WIRING DIAGRAMS BMW - X5

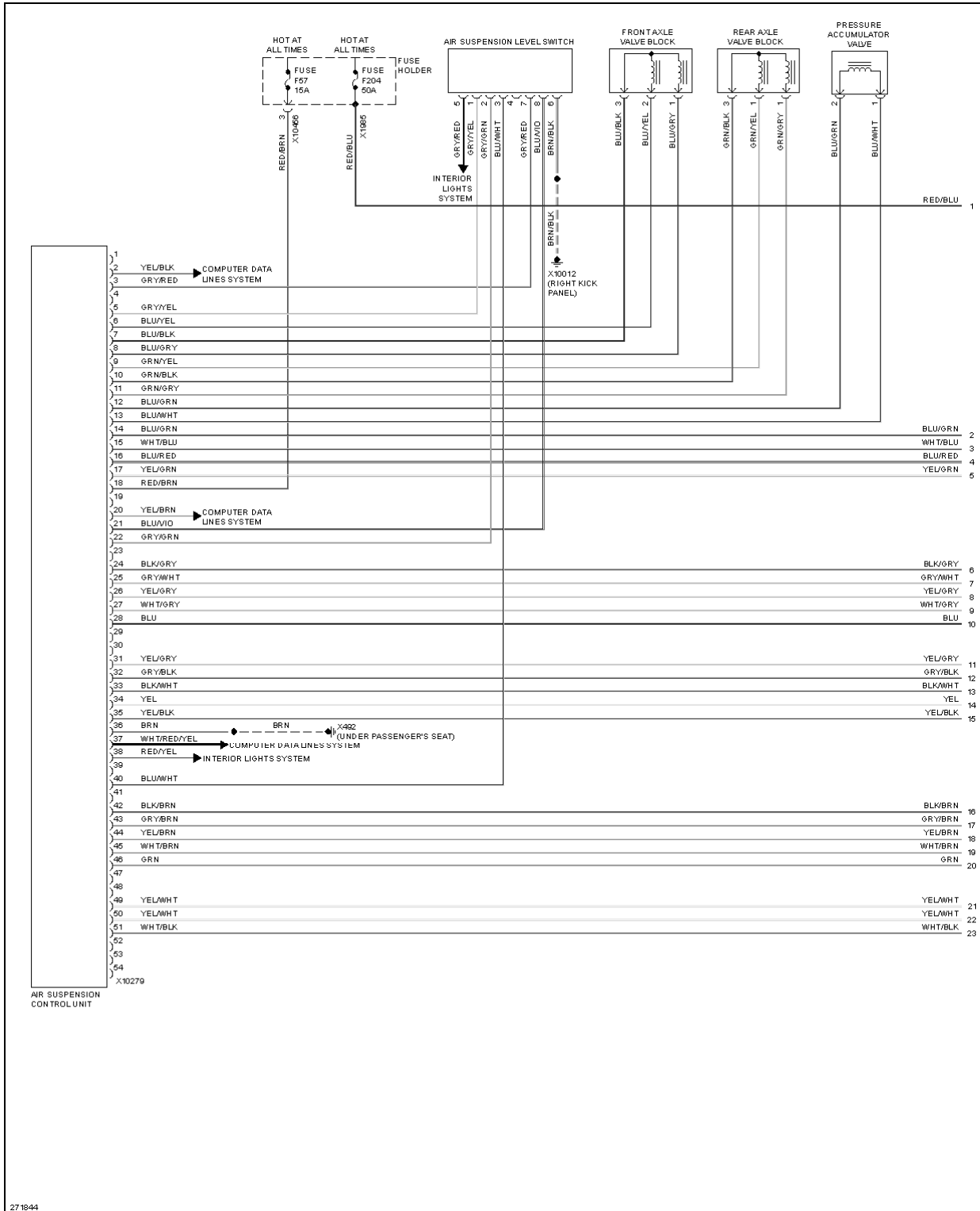

Fig. 26: Electronic Suspension Circuit, W/ Dual Axle (1 of 2)

2004 BMW X5 30i

2004 SYSTEM WIRING DIAGRAMS BMW - X5

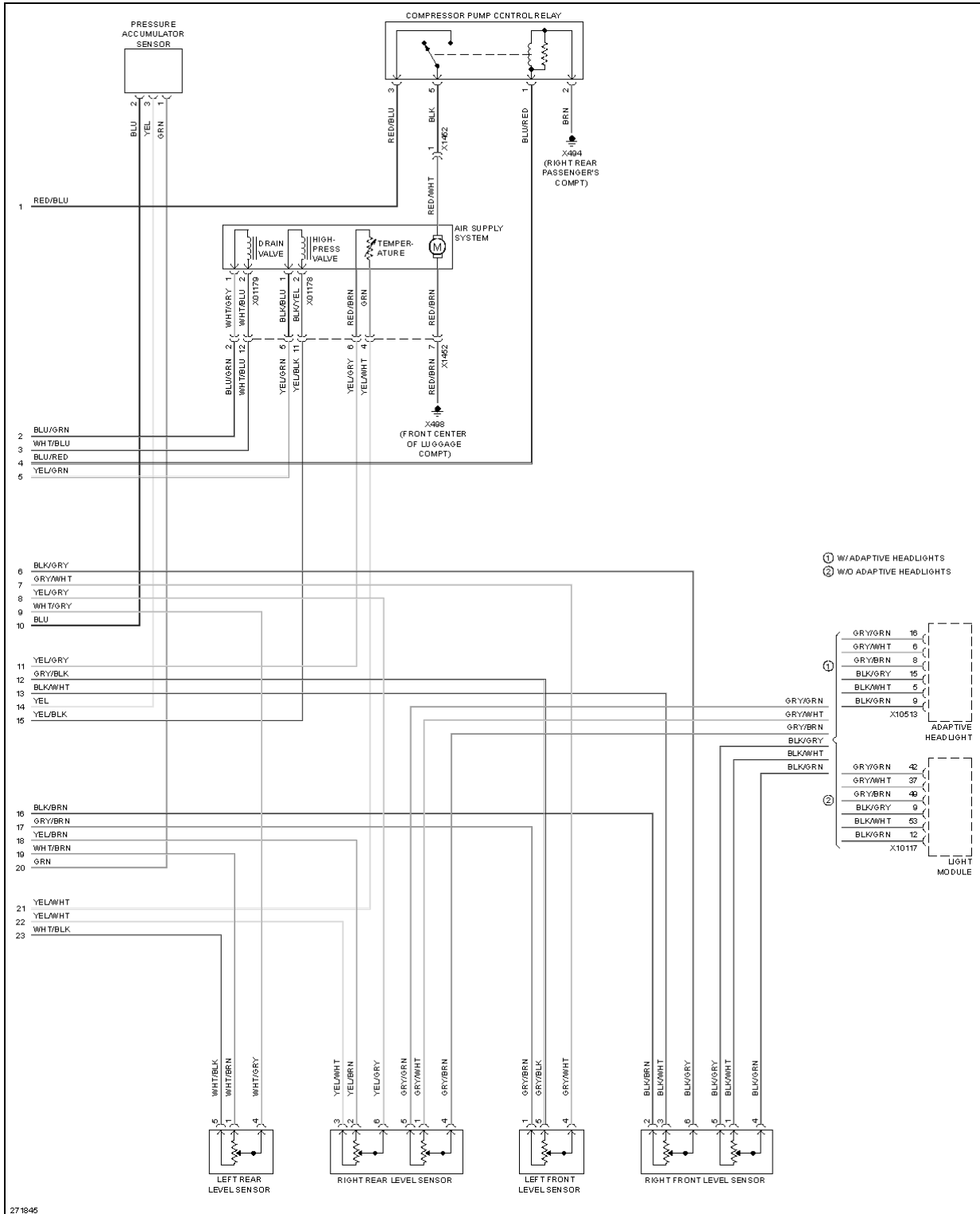

Fig. 27: Electronic Suspension Circuit, W/ Dual Axle (2 of 2)

2004 BMW X5 30i

2004 SYSTEM WIRING DIAGRAMS BMW - X5

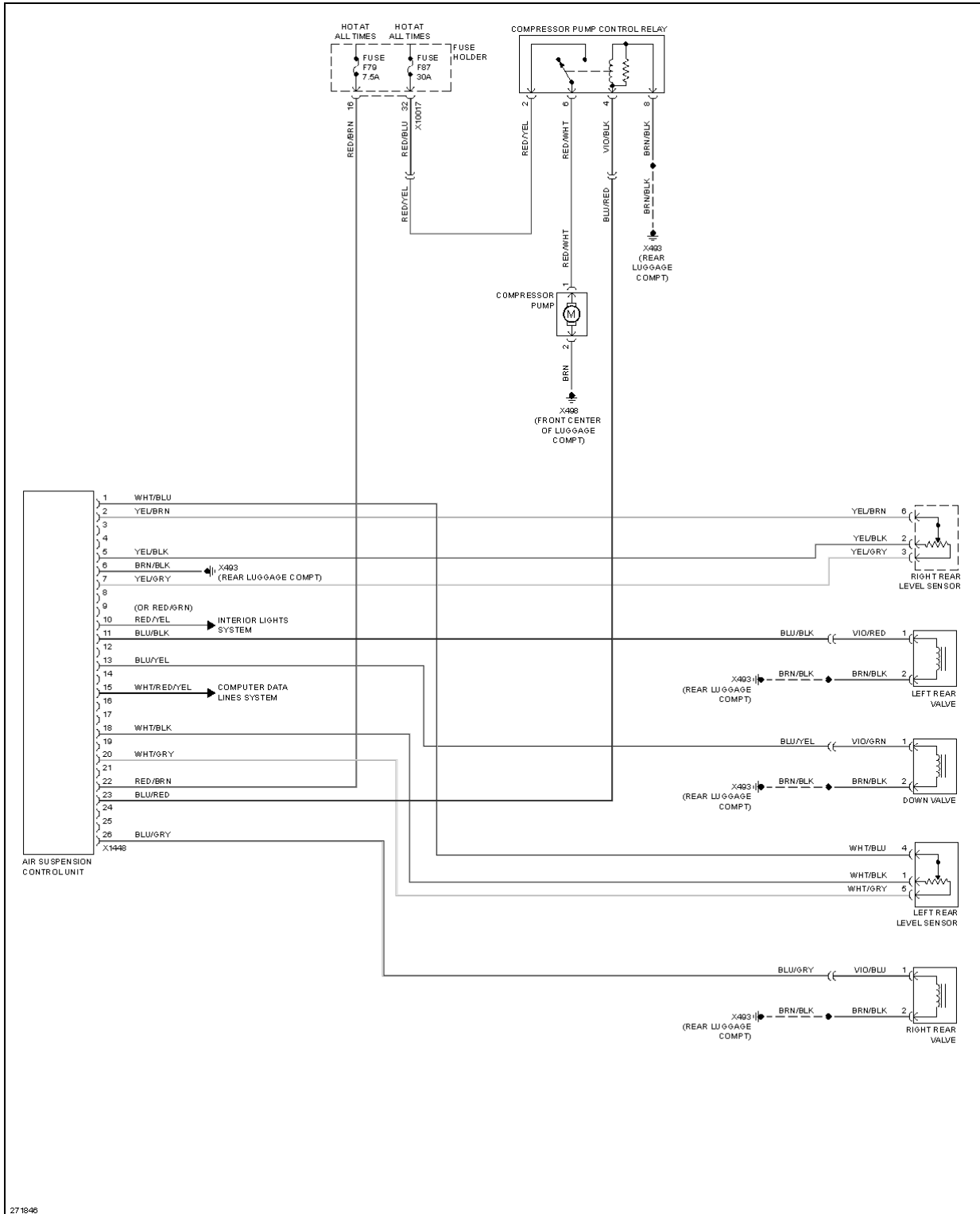

Fig. 28: Electronic Suspension Circuit, W/ Single Axle

ENGINE PERFORMANCE

3.0L

2004 BMW X5 30i

2004 SYSTEM WIRING DIAGRAMS BMW - X5

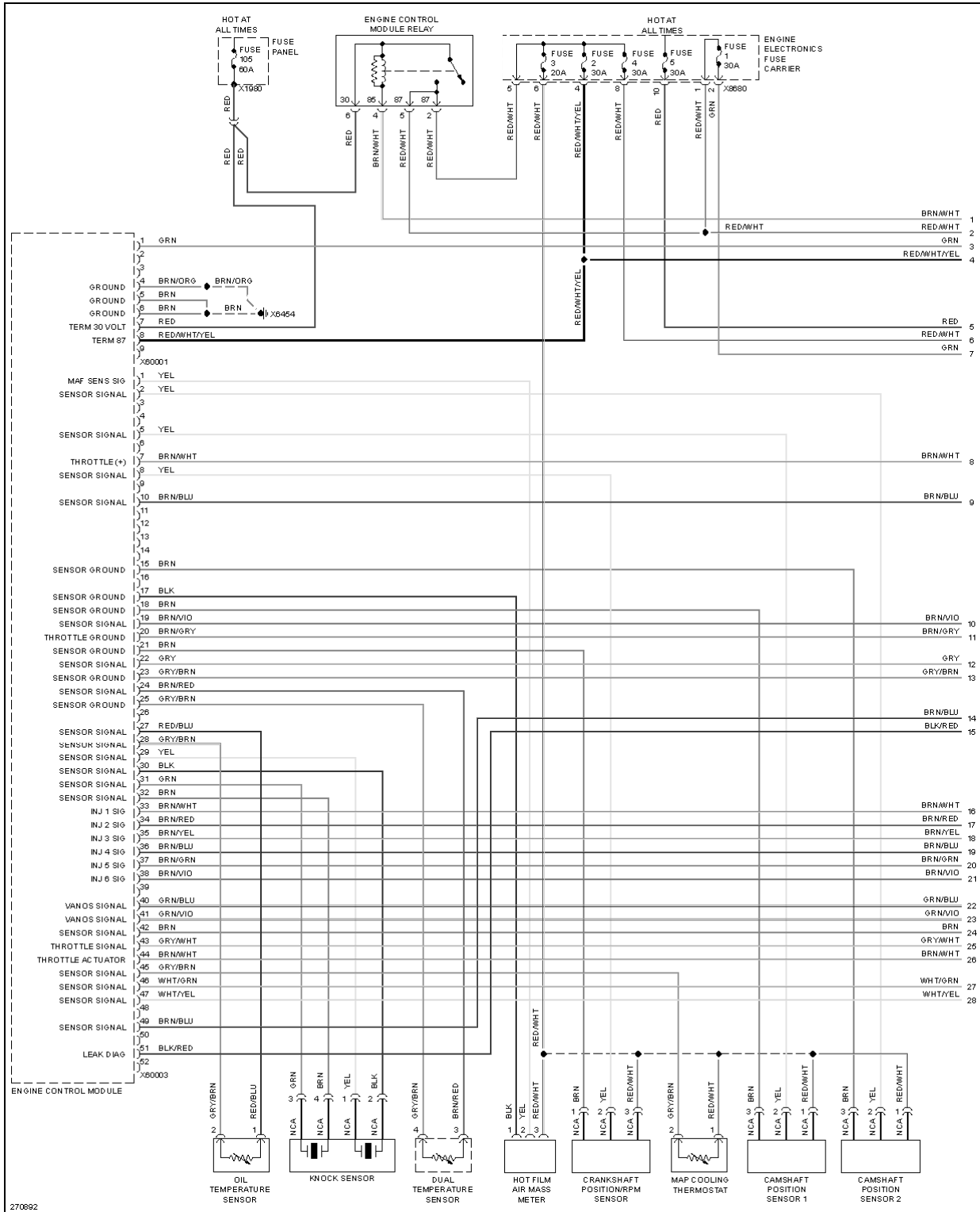

Fig. 29: 3.0L, Engine Performance Circuit (1 of 4)

2004 BMW X5 30i

2004 SYSTEM WIRING DIAGRAMS BMW - X5

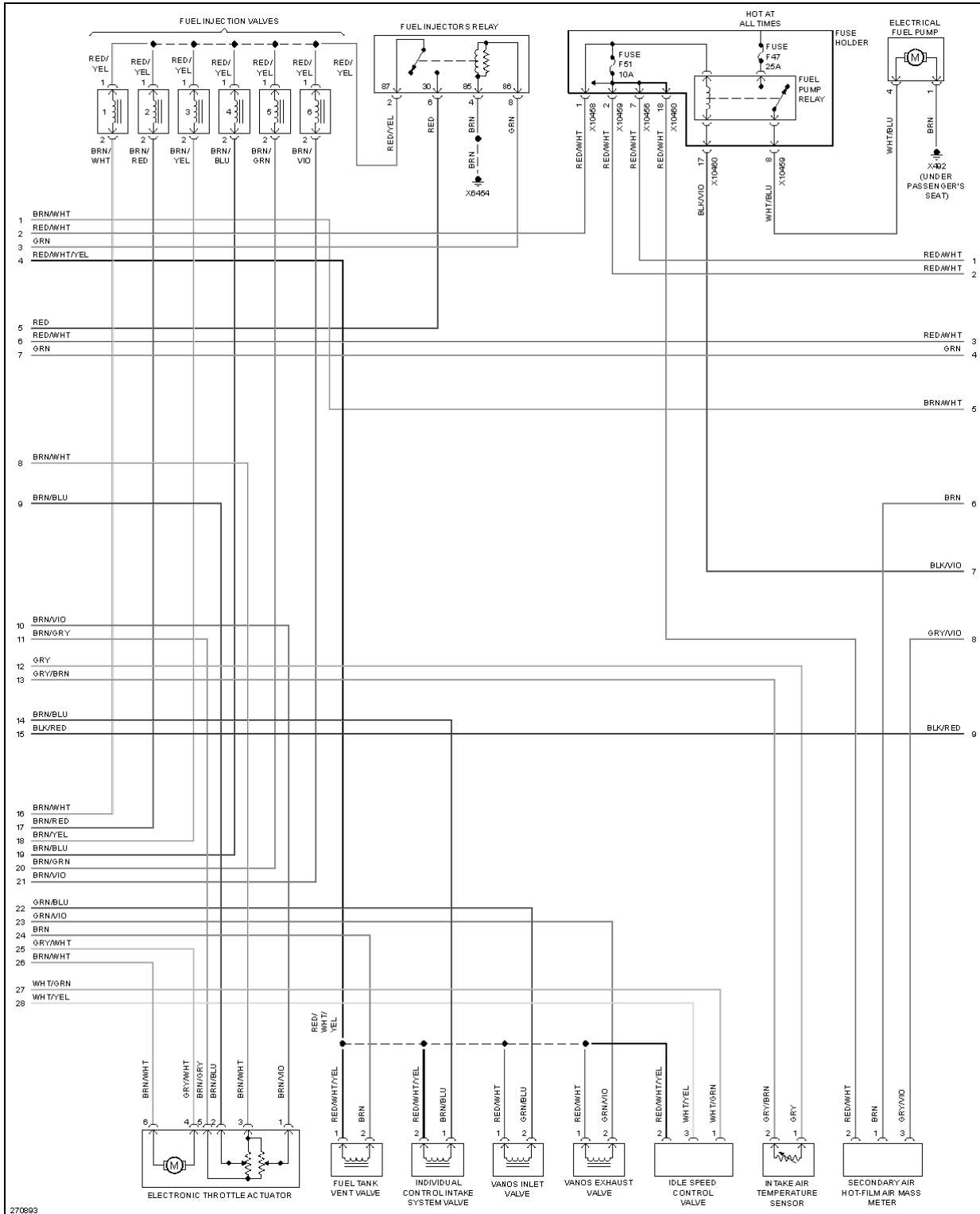

Fig. 30: 3.0L, Engine Performance Circuit (2 of 4)

2004 BMW X5 30i

2004 SYSTEM WIRING DIAGRAMS BMW - X5

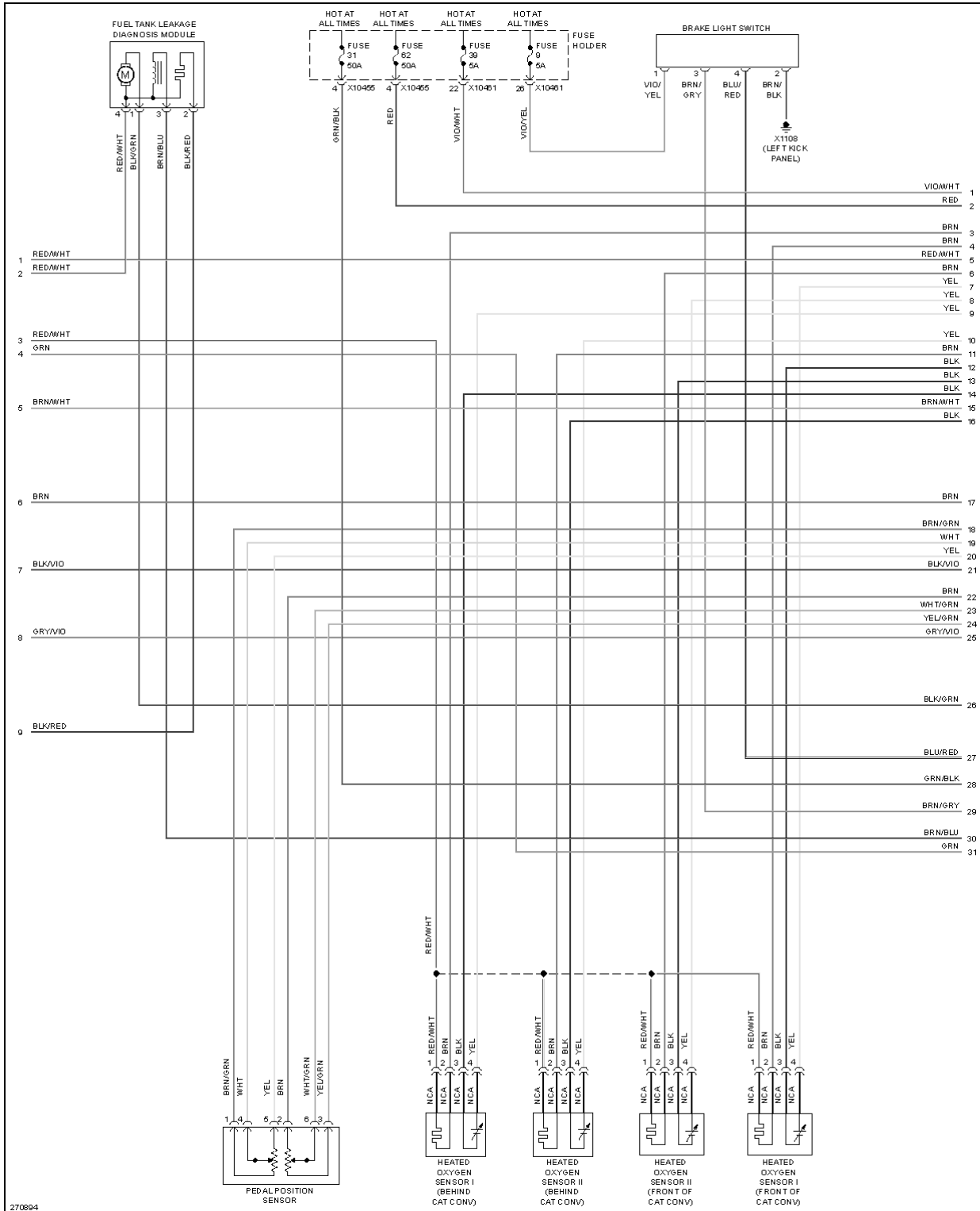

Fig. 31: 3.0L, Engine Performance Circuit (3 of 4)

2004 BMW X5 30i

2004 SYSTEM WIRING DIAGRAMS BMW - X5

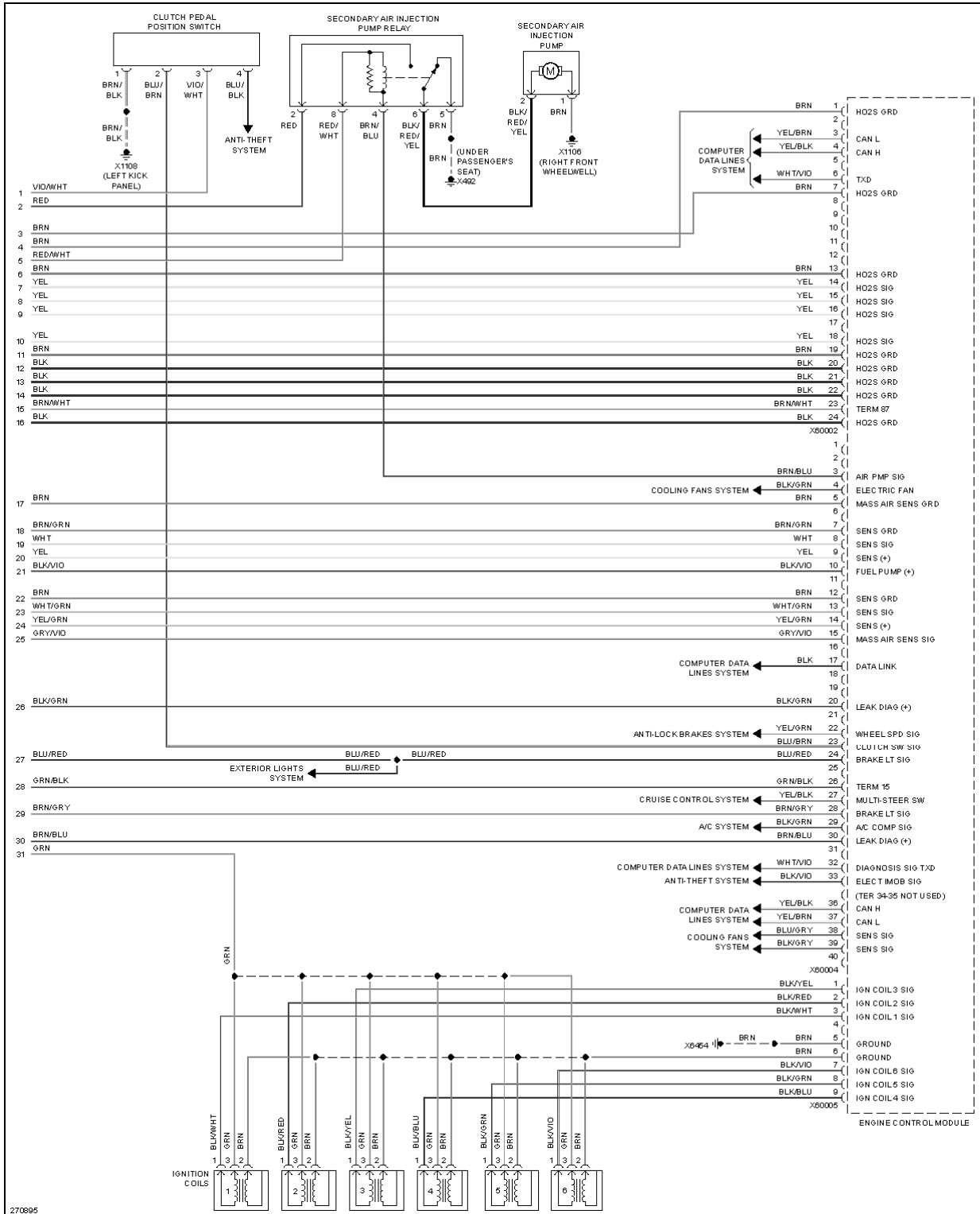

Fig. 32: 3.0L, Engine Performance Circuit (4 of 4)

4.4L

2004 BMW X5 30i

2004 SYSTEM WIRING DIAGRAMS BMW - X5

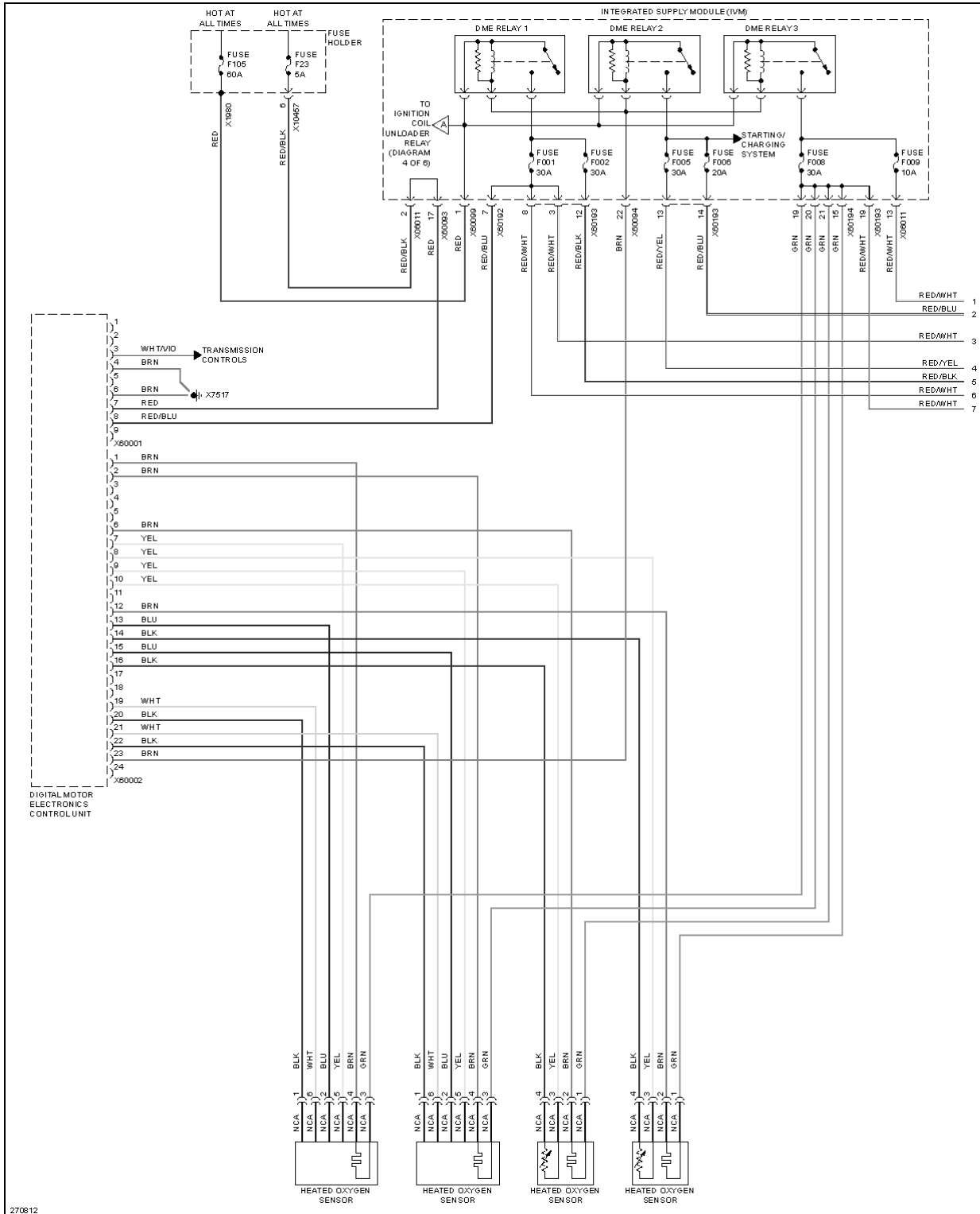

Fig. 33: 4.4L, Engine Performance Circuit (1 of 6)

2004 BMW X5 30i

2004 SYSTEM WIRING DIAGRAMS BMW - X5

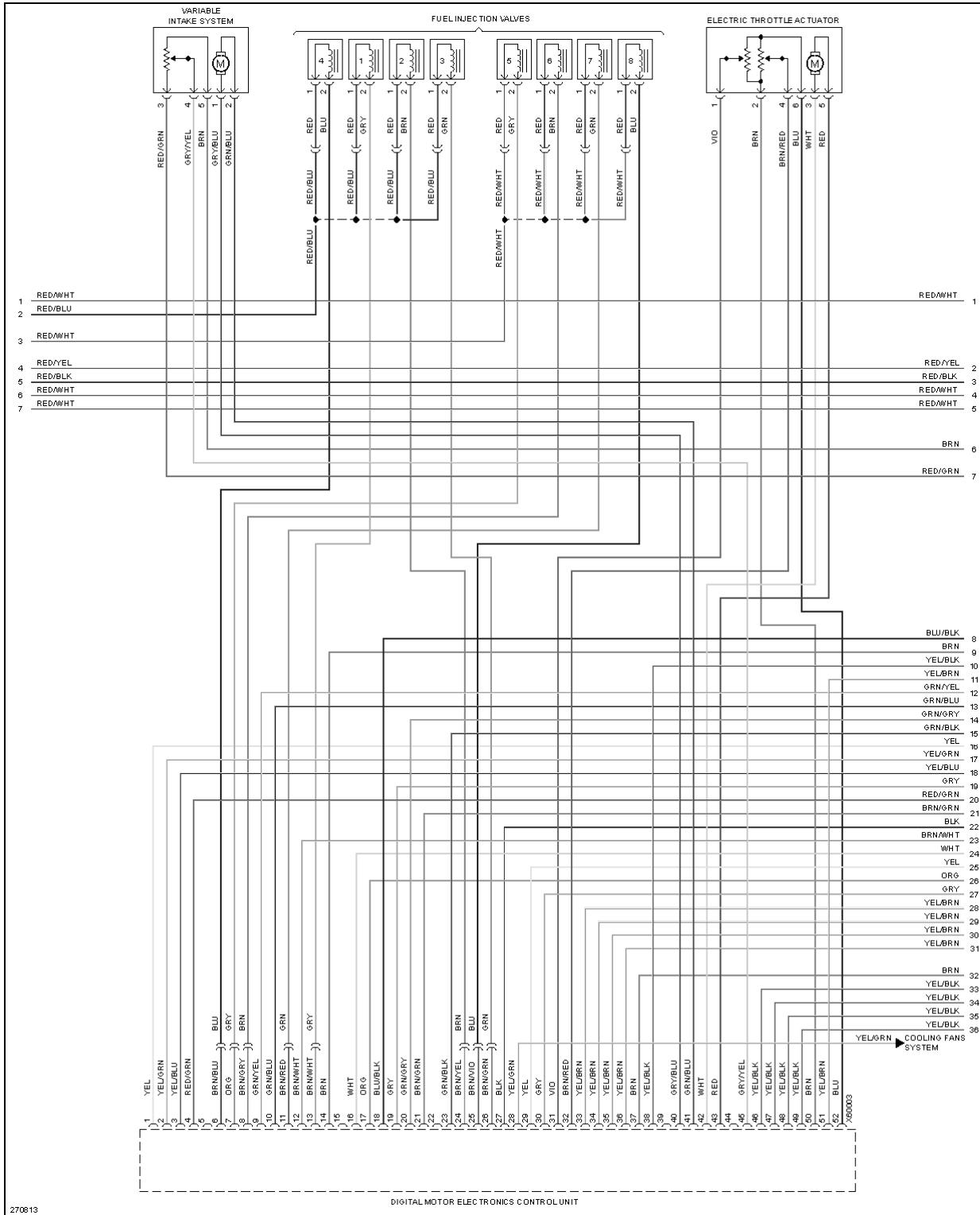

Fig. 34: 4.4L, Engine Performance Circuit (2 of 6)

2004 BMW X5 30i

2004 SYSTEM WIRING DIAGRAMS BMW - X5

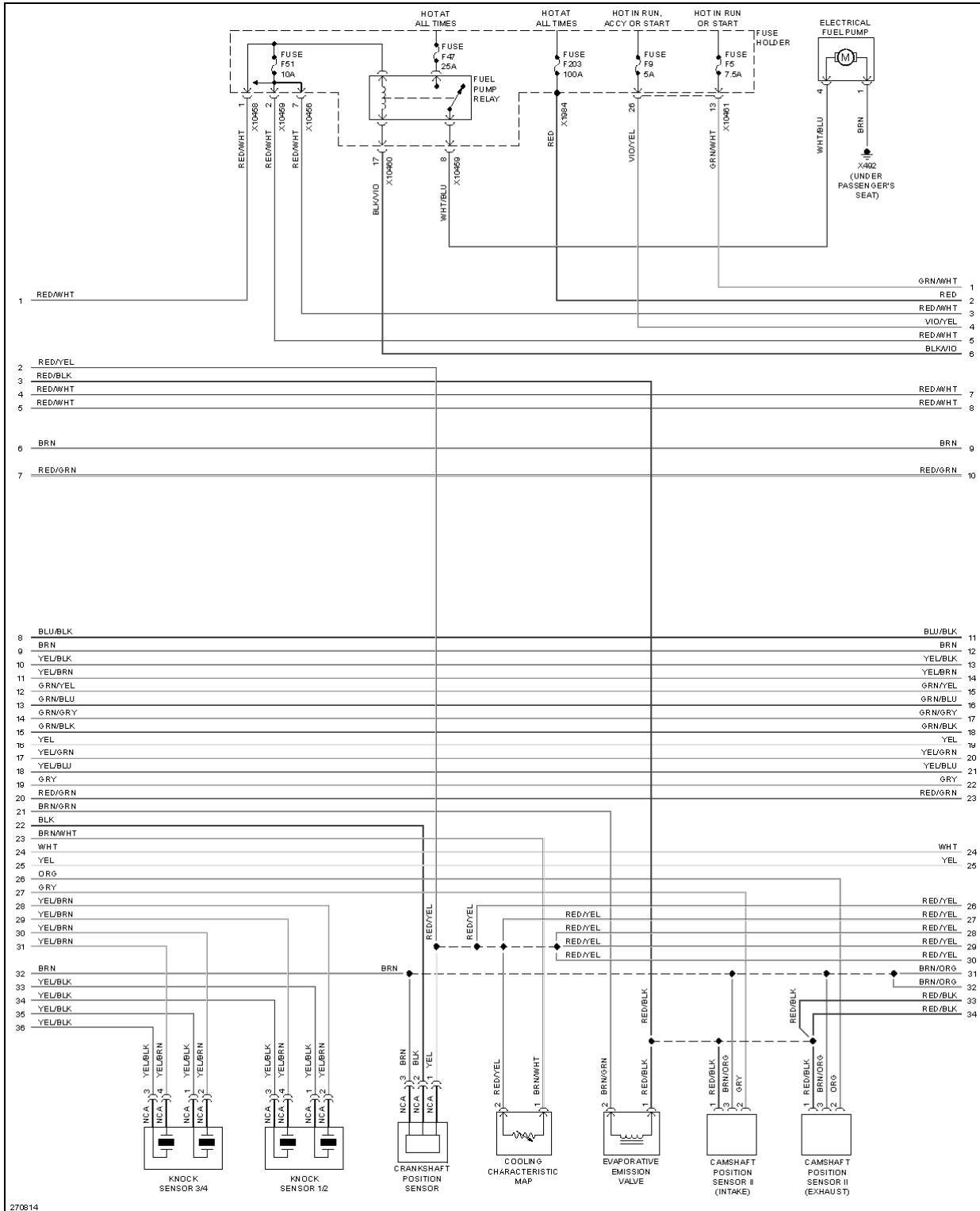

Fig. 35: 4.4L, Engine Performance Circuit (3 of 6)

2004 BMW X5 30i

2004 SYSTEM WIRING DIAGRAMS BMW - X5

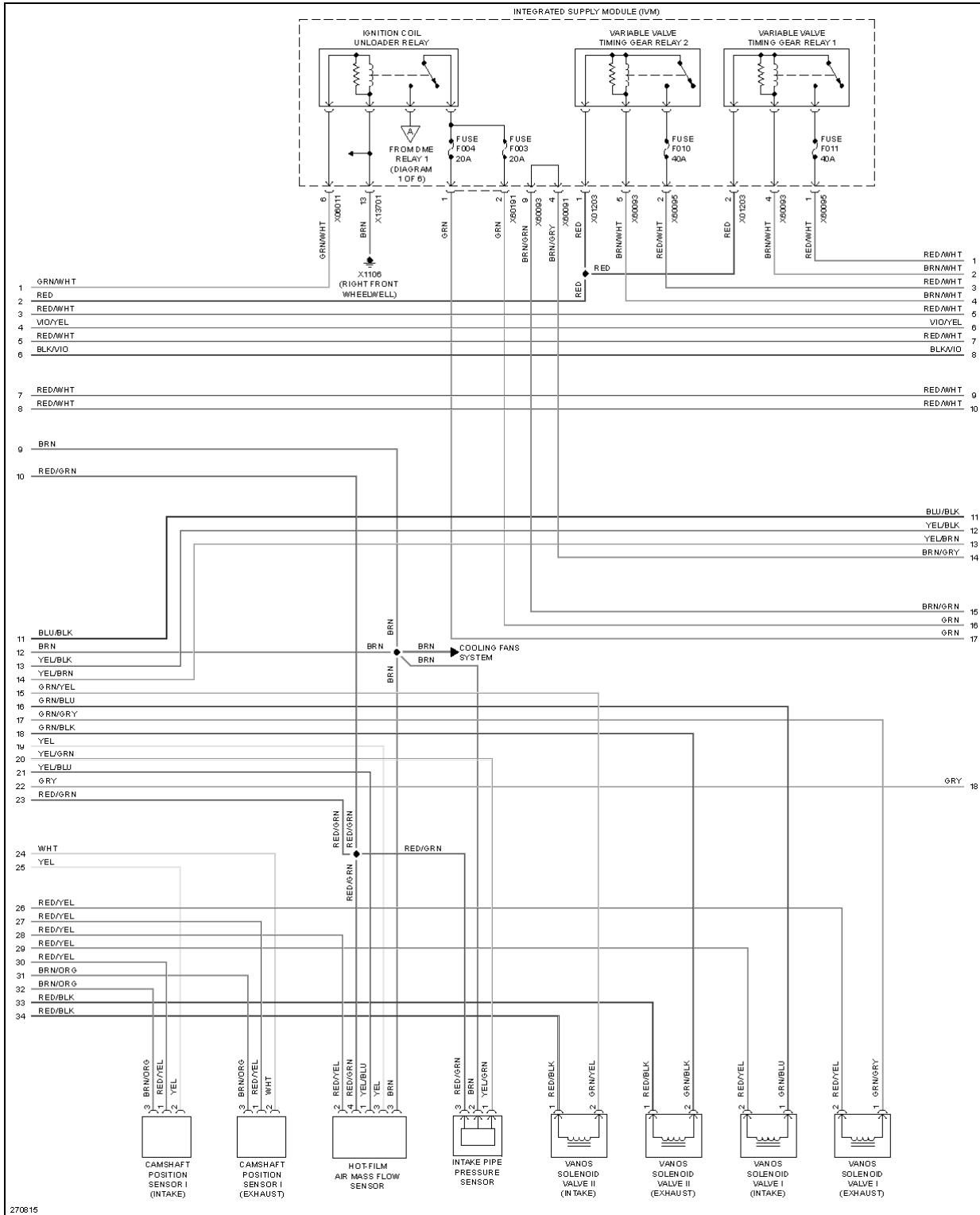

Fig. 36: 4.4L, Engine Performance Circuit (4 of 6)

2004 BMW X5 30i

2004 SYSTEM WIRING DIAGRAMS BMW - X5

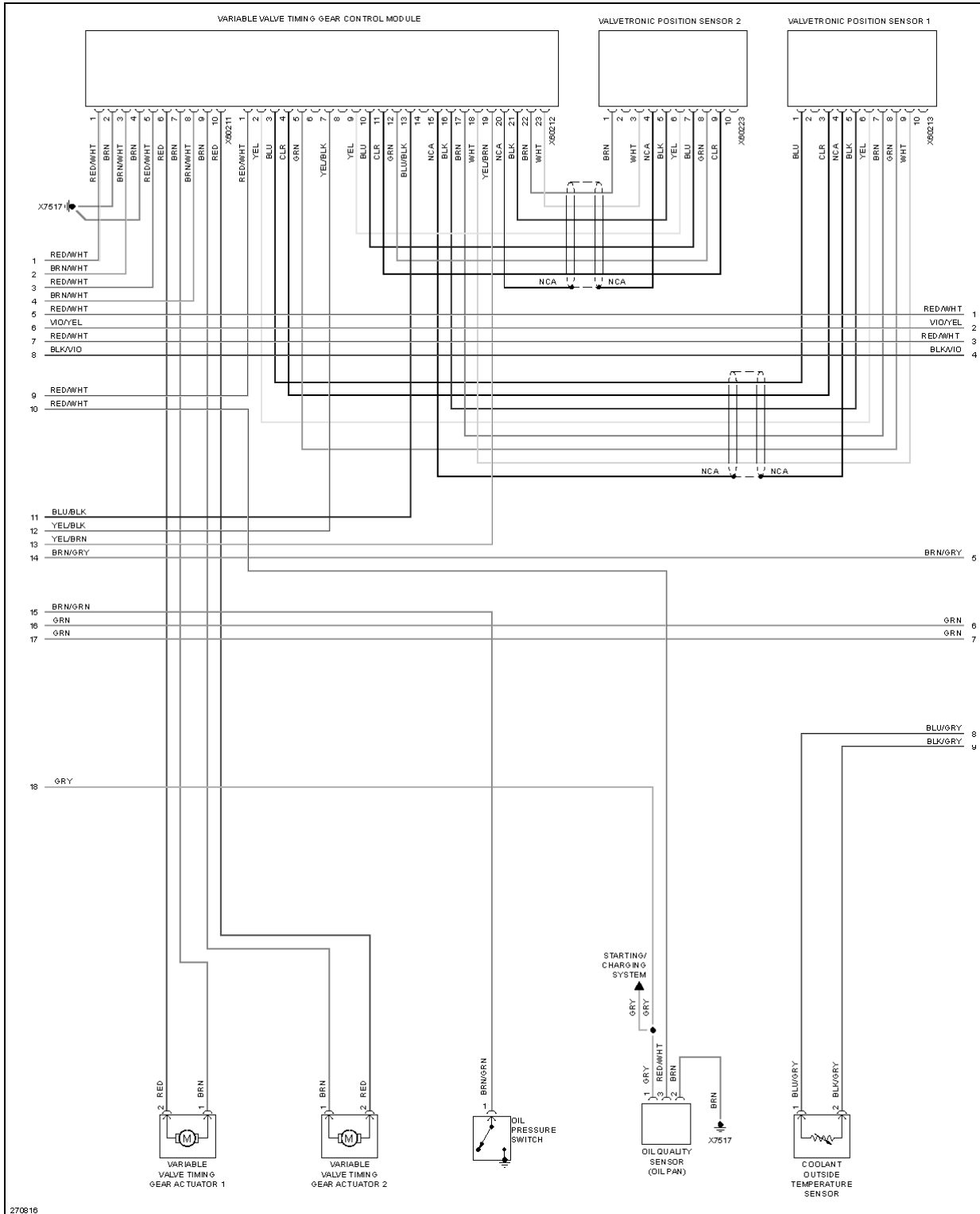

Fig. 37: 4.4L, Engine Performance Circuit (5 of 6)

2004 BMW X5 30i

2004 SYSTEM WIRING DIAGRAMS BMW - X5

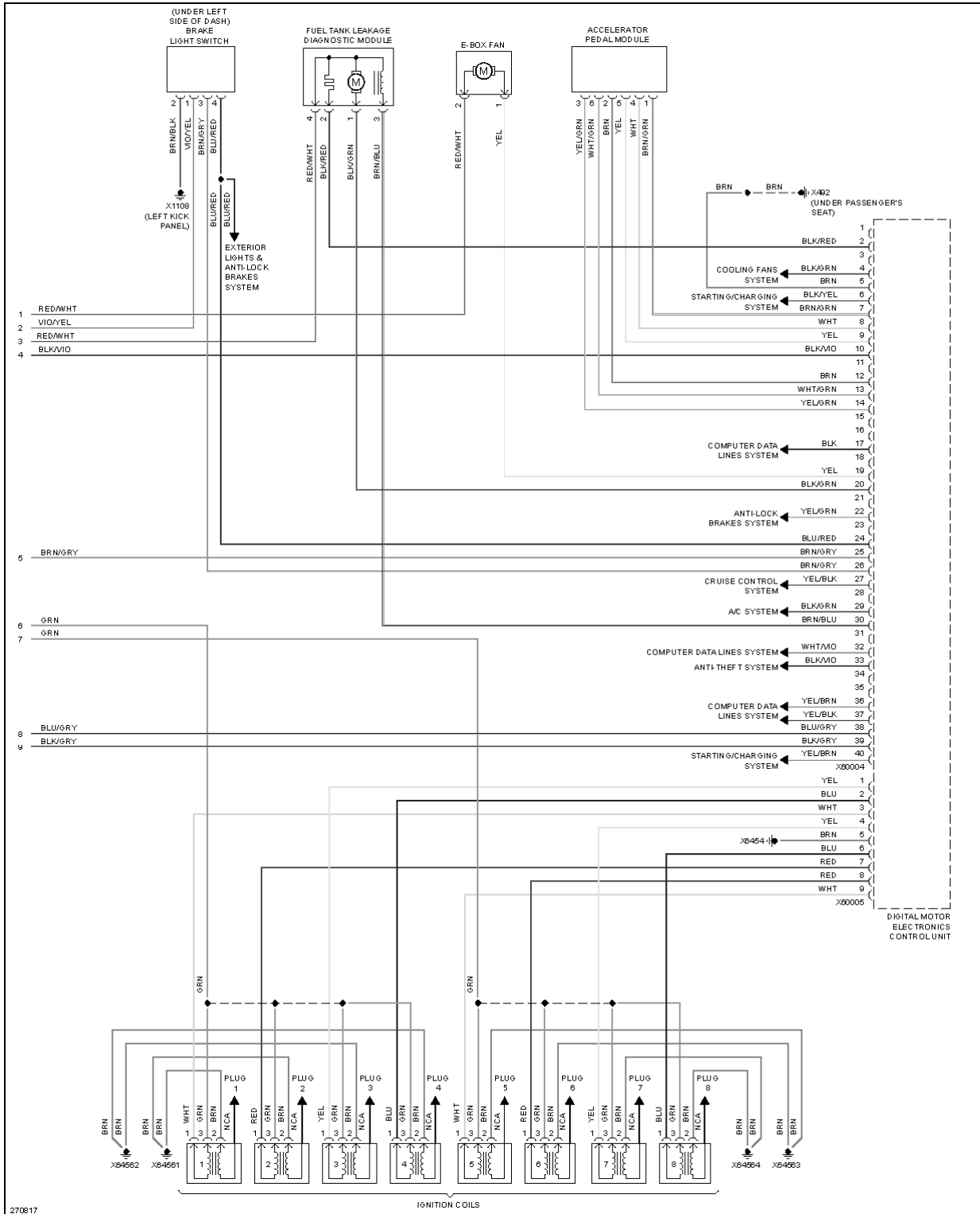

Fig. 38: 4.4L, Engine Performance Circuit (6 of 6)

4.8L

2004 BMW X5 30i

2004 SYSTEM WIRING DIAGRAMS BMW - X5

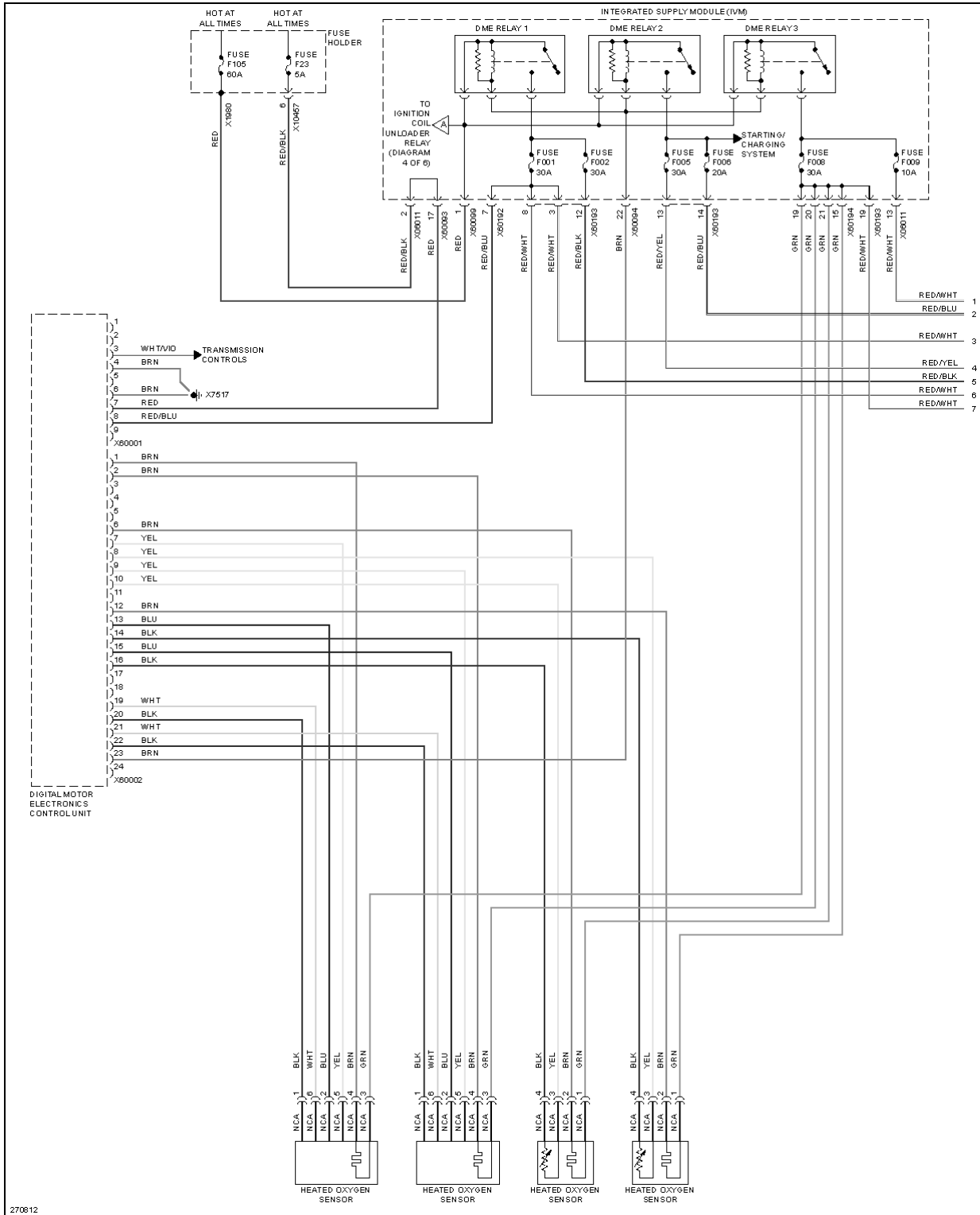

Fig. 39: 4.8L, Engine Performance Circuit (1 of 6)

2004 BMW X5 30i

2004 SYSTEM WIRING DIAGRAMS BMW - X5

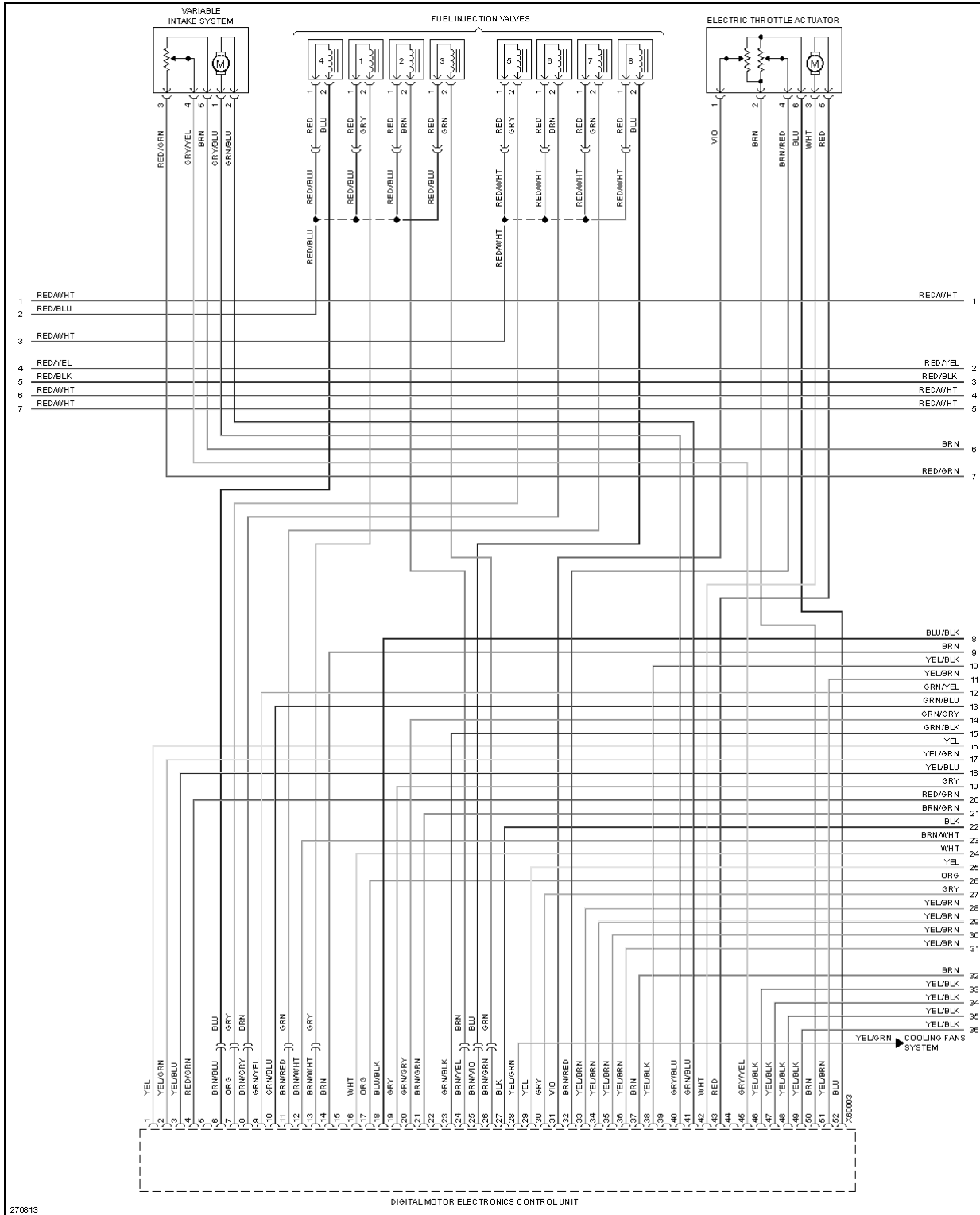

Fig. 40: 4.8L, Engine Performance Circuit (2 of 6)

2004 BMW X5 30i

2004 SYSTEM WIRING DIAGRAMS BMW - X5

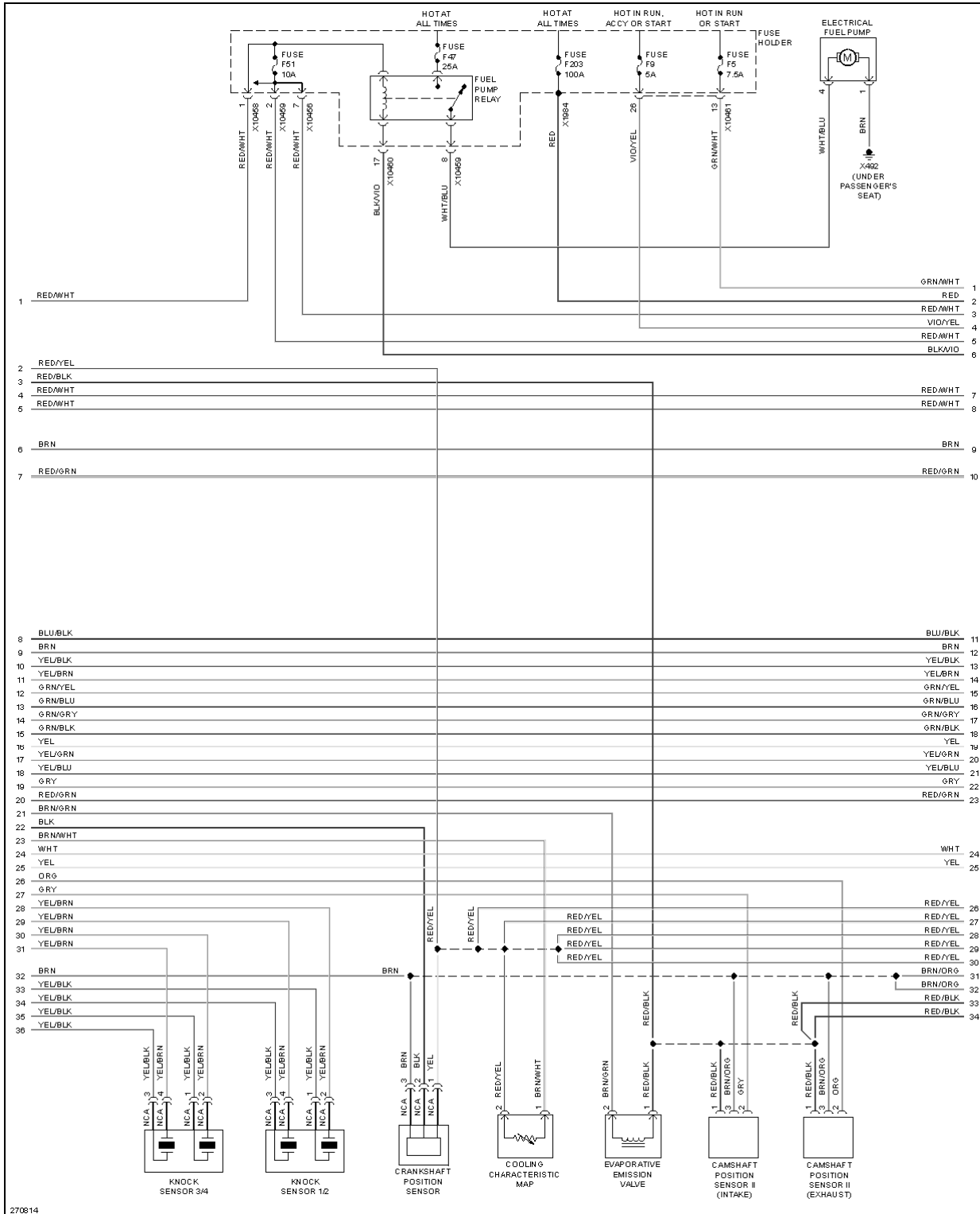

Fig. 41: 4.8L, Engine Performance Circuit (3 of 6)

2004 BMW X5 30i

2004 SYSTEM WIRING DIAGRAMS BMW - X5

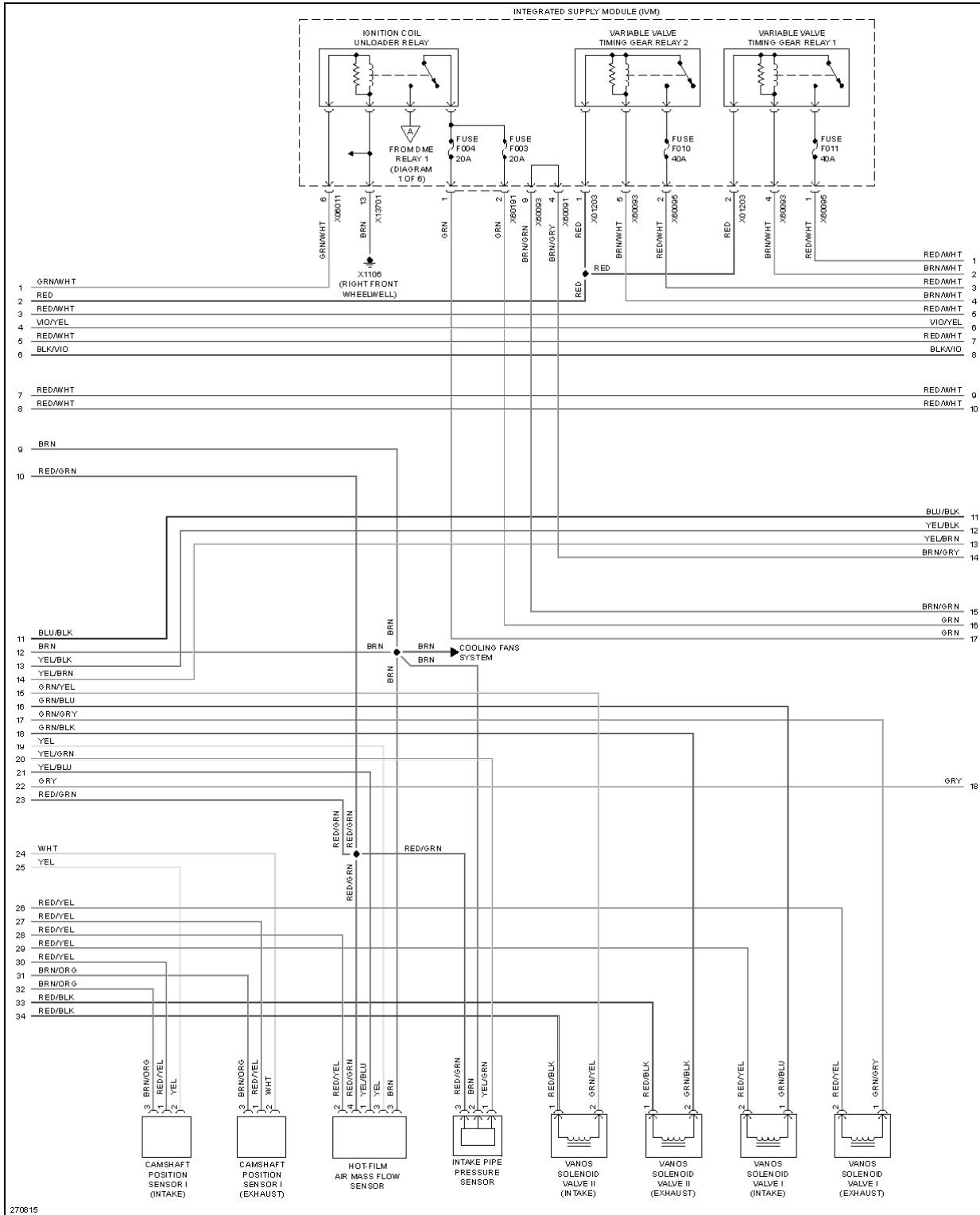

Fig. 42: 4.8L, Engine Performance Circuit (4 of 6)

2004 BMW X5 30i

2004 SYSTEM WIRING DIAGRAMS BMW - X5

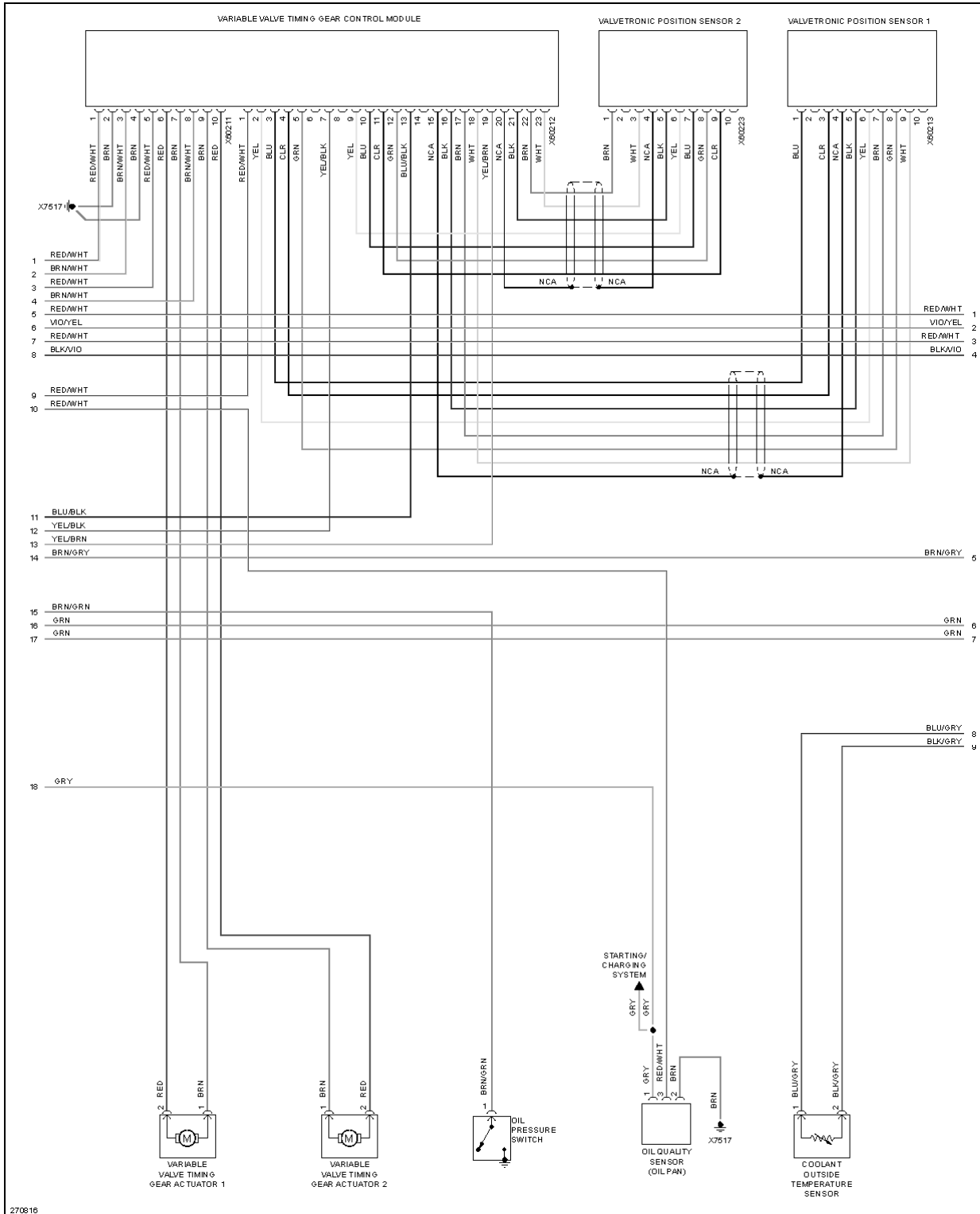

Fig. 43: 4.8L, Engine Performance Circuit (5 of 6)

2004 BMW X5 30i

2004 SYSTEM WIRING DIAGRAMS BMW - X5

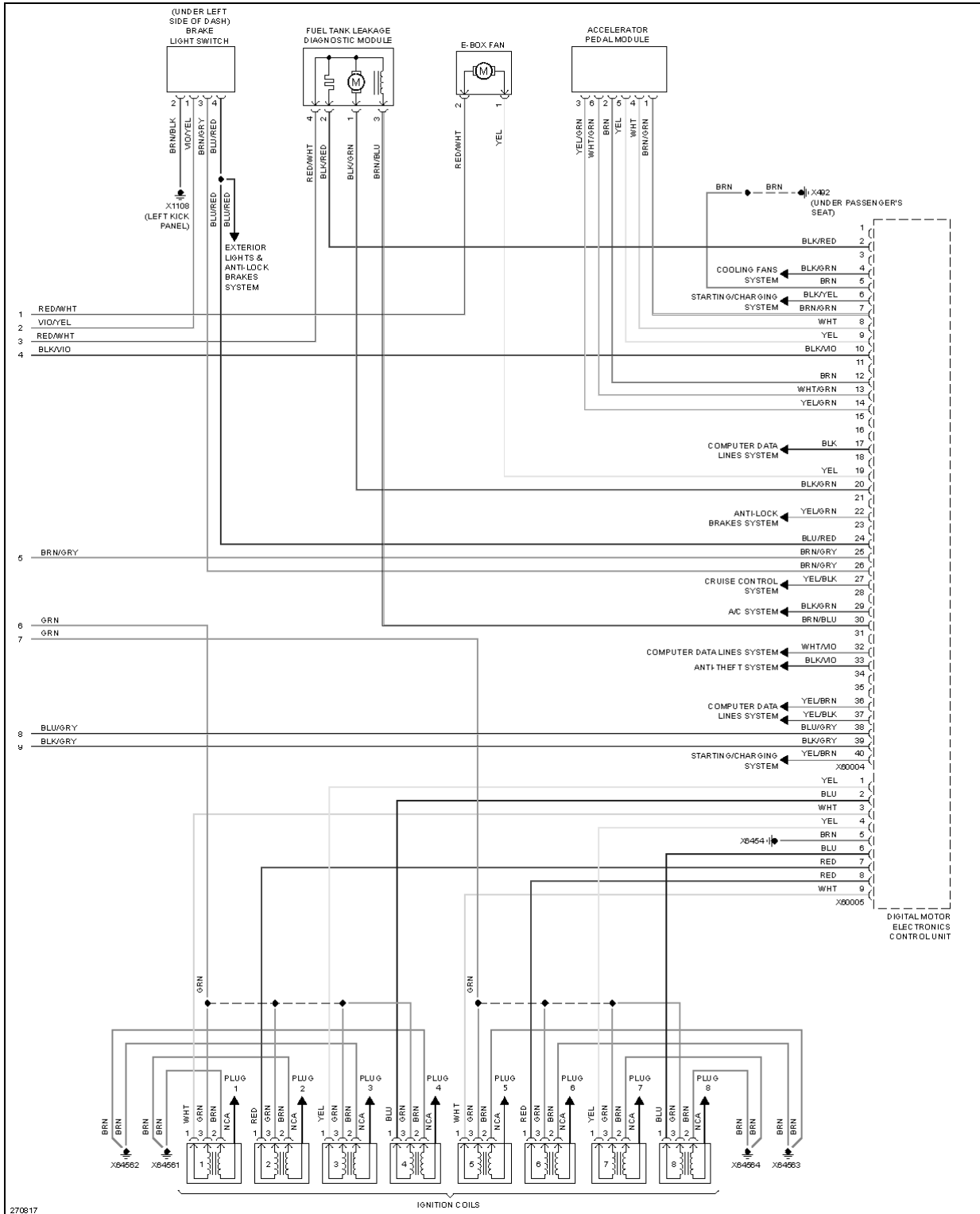

Fig. 44: 4.8L, Engine Performance Circuit (6 of 6)

EXTERIOR LIGHTS

2004 BMW X5 30i

2004 SYSTEM WIRING DIAGRAMS BMW - X5

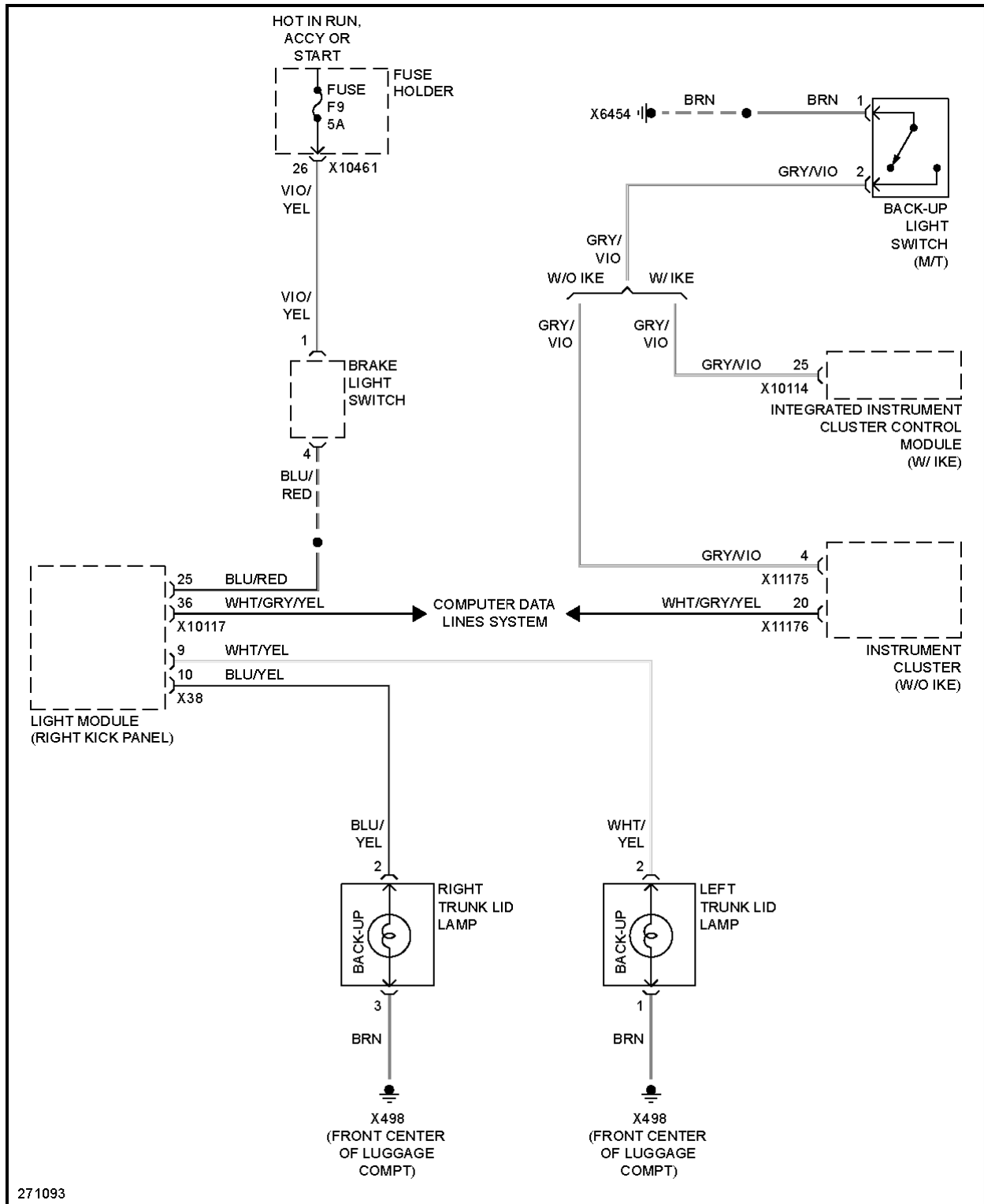

Fig. 45: Back-up Lamps Circuit

2004 BMW X5 30i

2004 SYSTEM WIRING DIAGRAMS BMW - X5

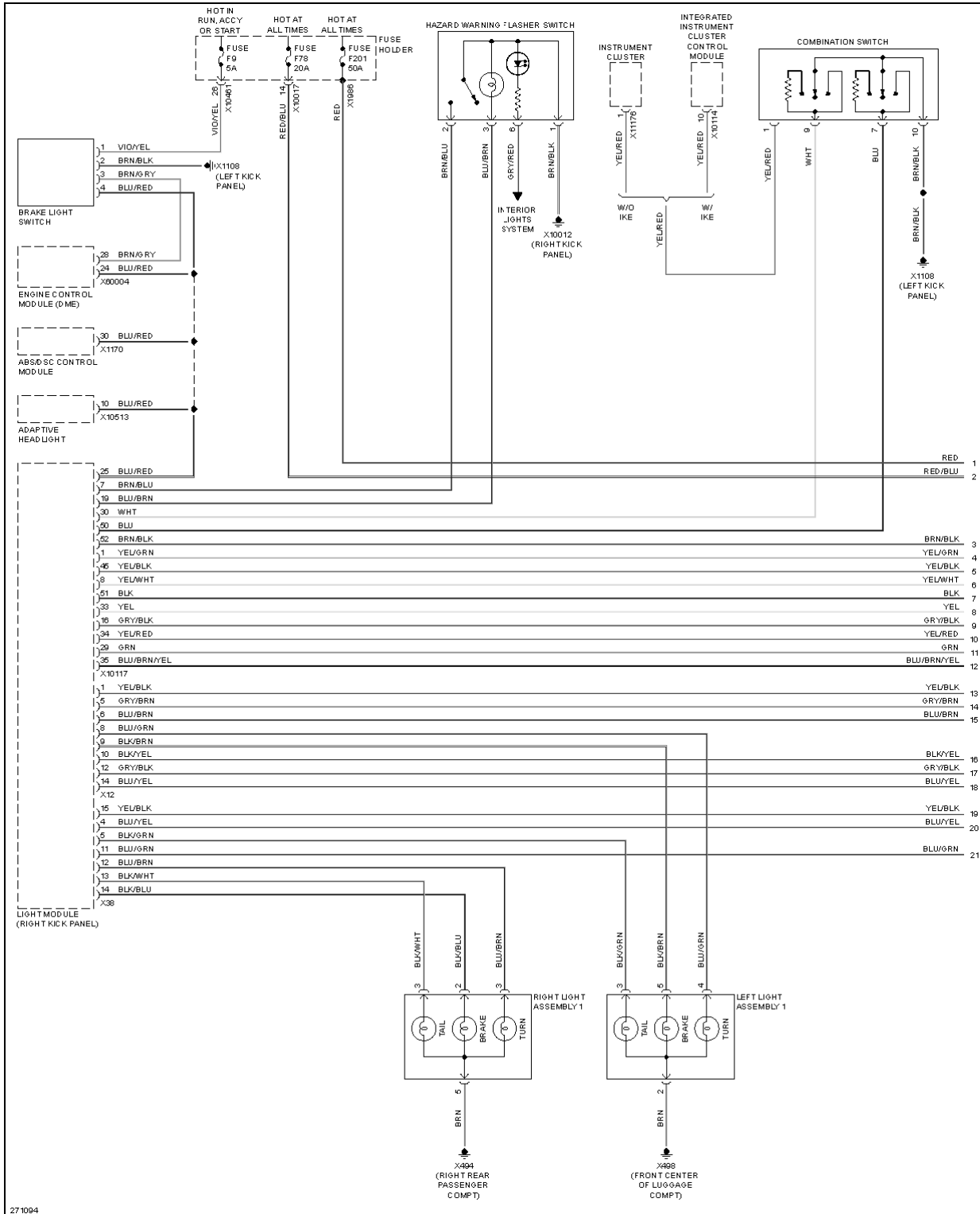

Fig. 46: Exterior Lamps Circuit (1 of 2)

2004 BMW X5 30i

2004 SYSTEM WIRING DIAGRAMS BMW - X5

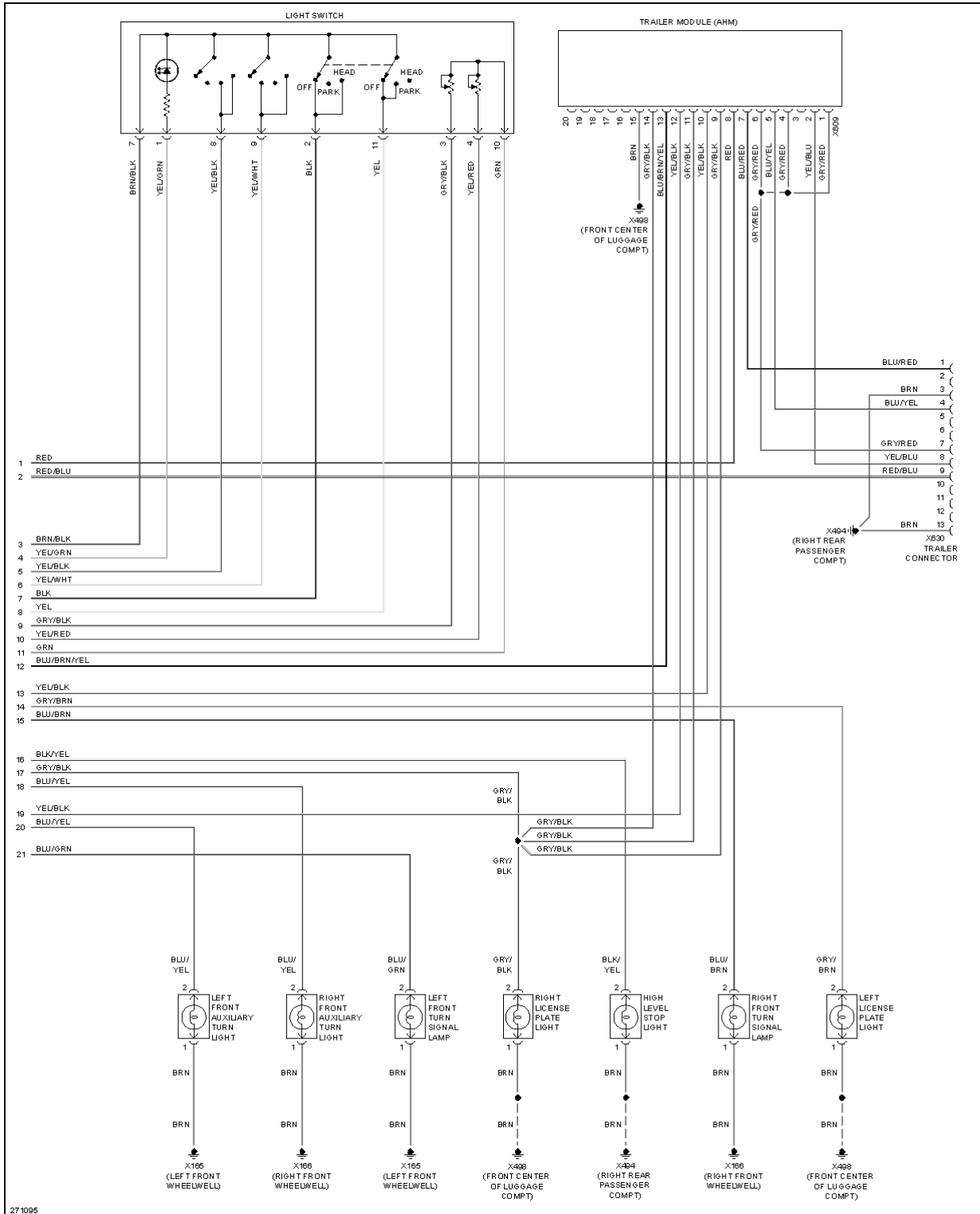

Fig. 47: Exterior Lamps Circuit (2 of 2)

GROUND DISTRIBUTION

2004 BMW X5 30i

2004 SYSTEM WIRING DIAGRAMS BMW - X5

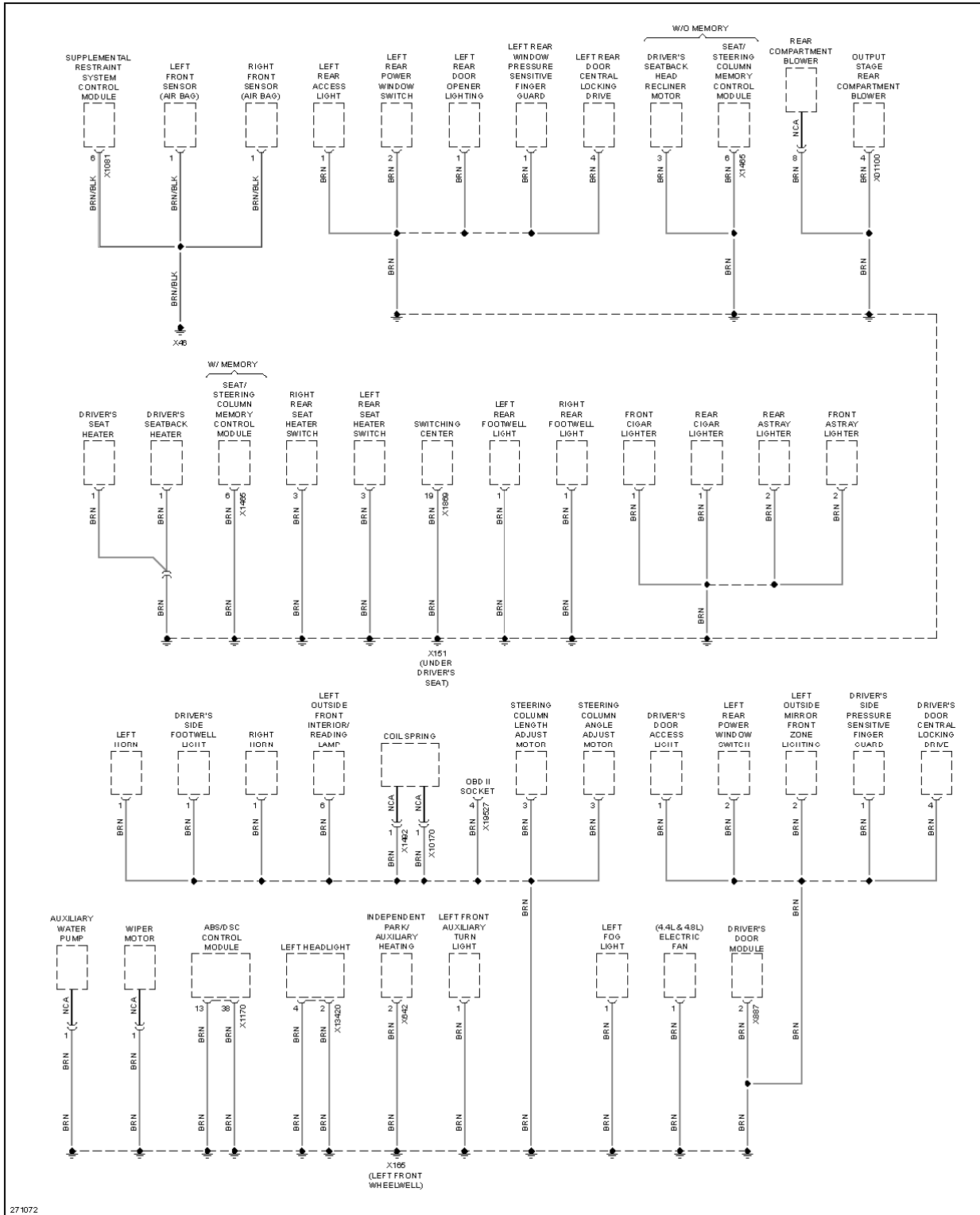

Fig. 48: Ground Distribution Circuit (1 of 5)

2004 BMW X5 30i

2004 SYSTEM WIRING DIAGRAMS BMW - X5

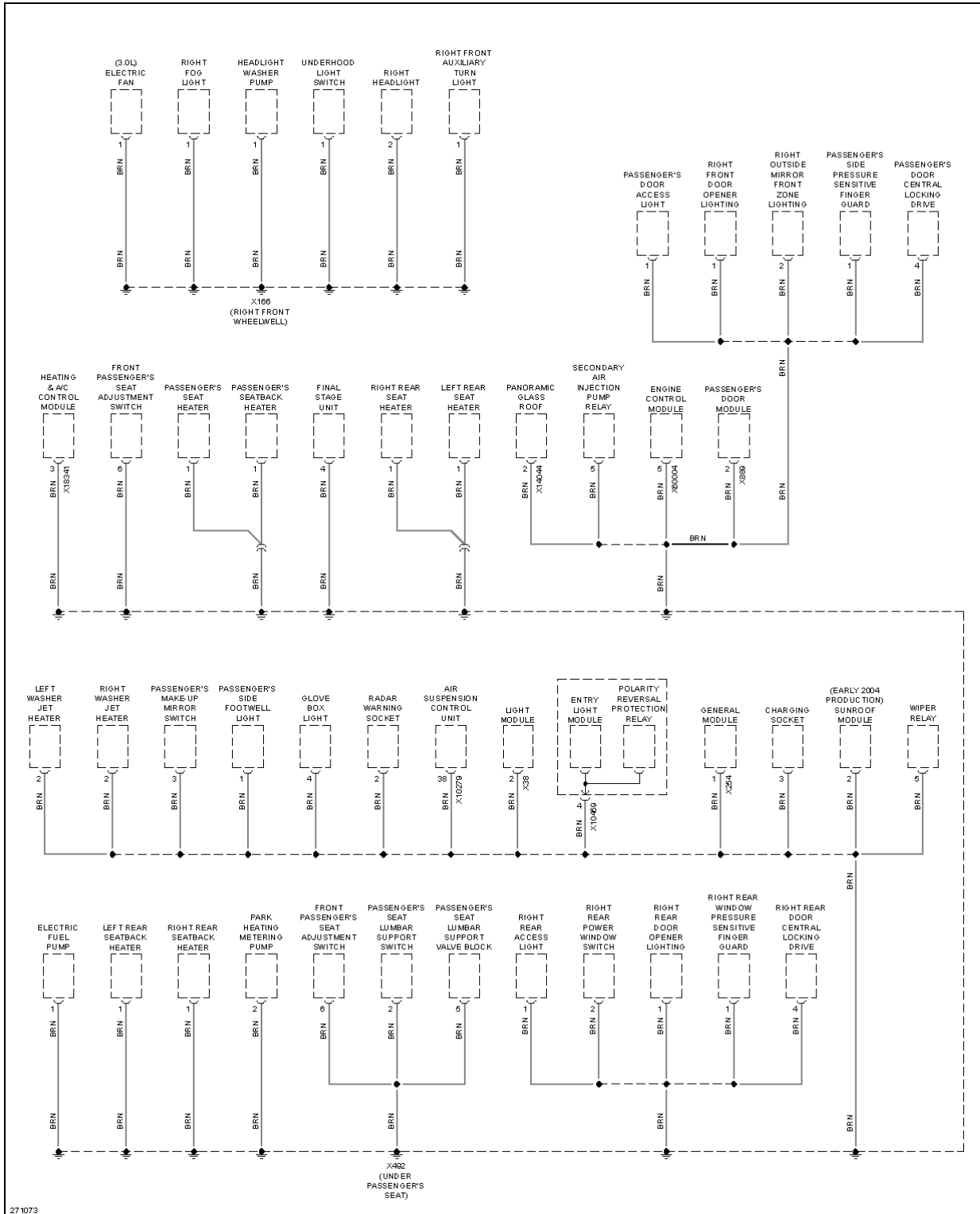

Fig. 49: Ground Distribution Circuit (2 of 5)

2004 BMW X5 30i

2004 SYSTEM WIRING DIAGRAMS BMW - X5

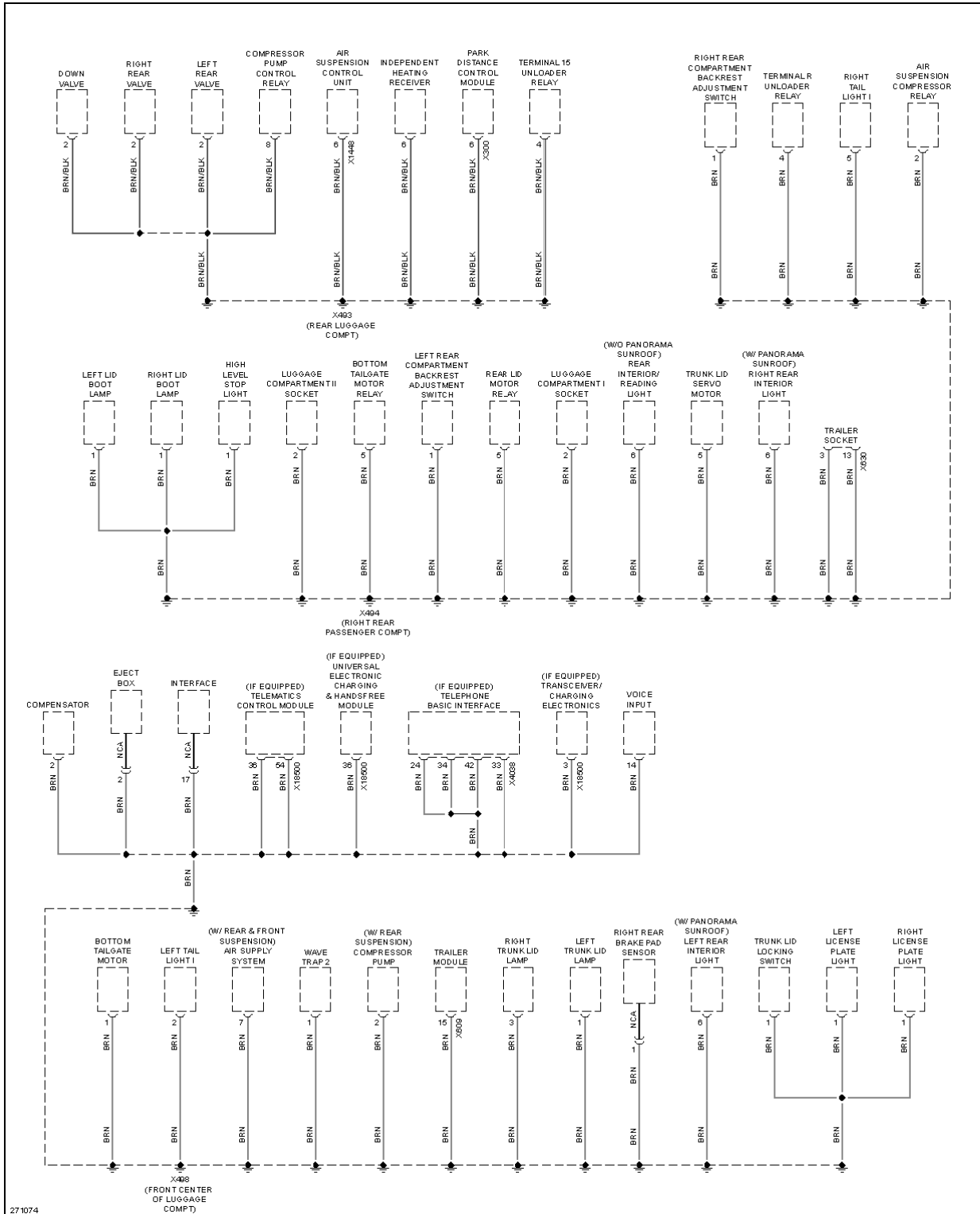

Fig. 50: Ground Distribution Circuit (3 of 5)

2004 BMW X5 30i

2004 SYSTEM WIRING DIAGRAMS BMW - X5

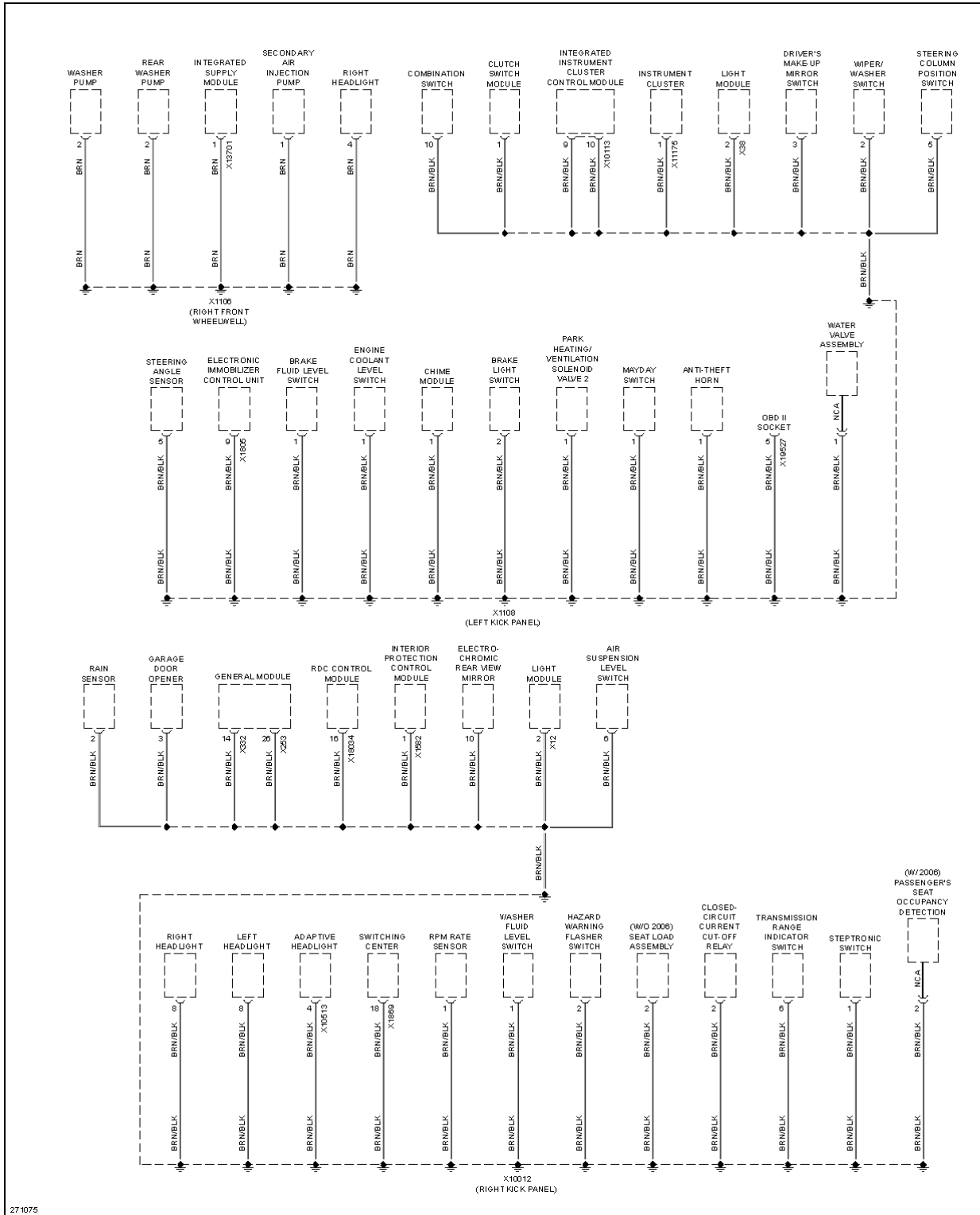

Fig. 51: Ground Distribution Circuit (4 of 5)

2004 BMW X5 30i

2004 SYSTEM WIRING DIAGRAMS BMW - X5

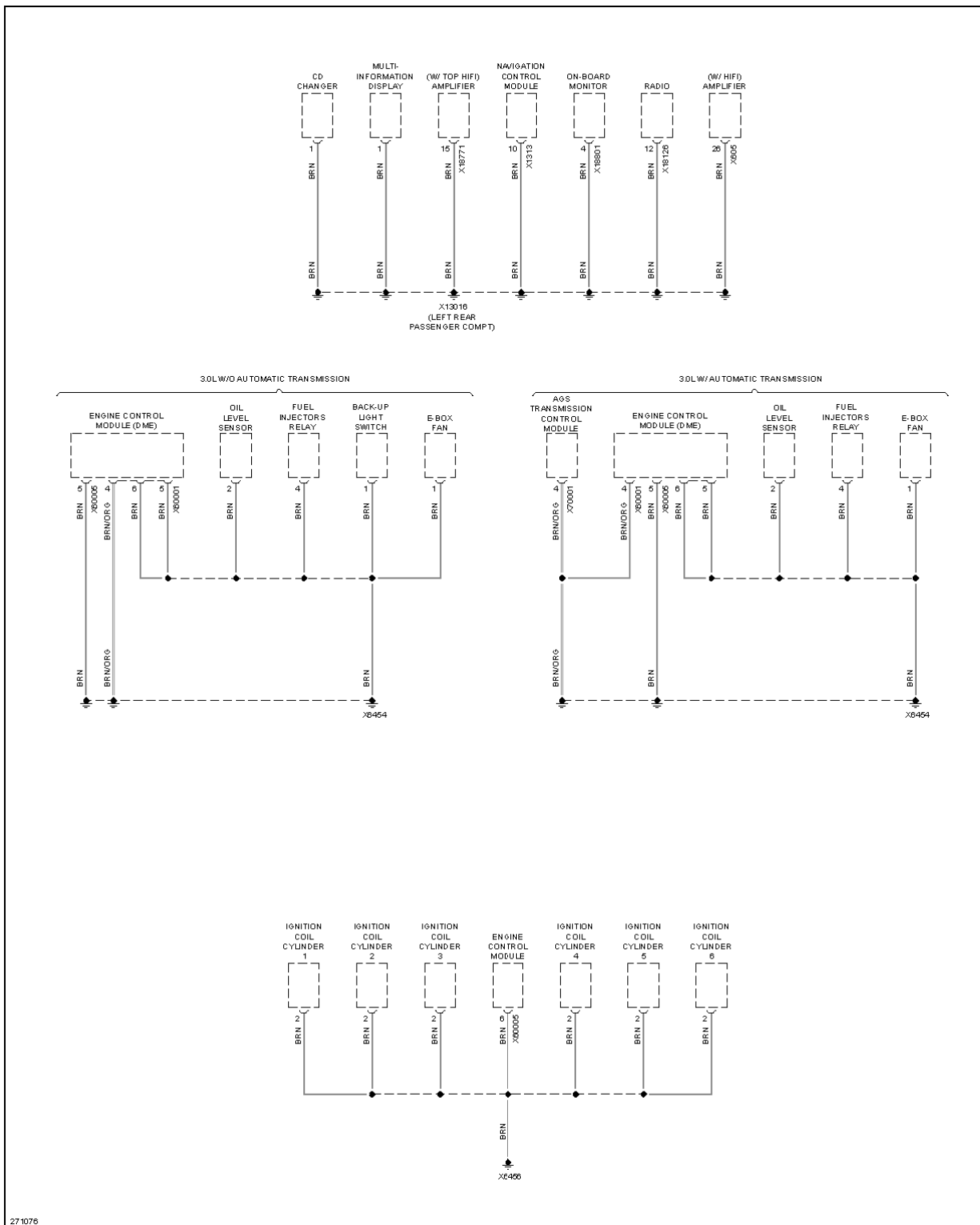

Fig. 52: Ground Distribution Circuit (5 of 5)

HEADLIGHTS

2004 BMW X5 30i

2004 SYSTEM WIRING DIAGRAMS BMW - X5

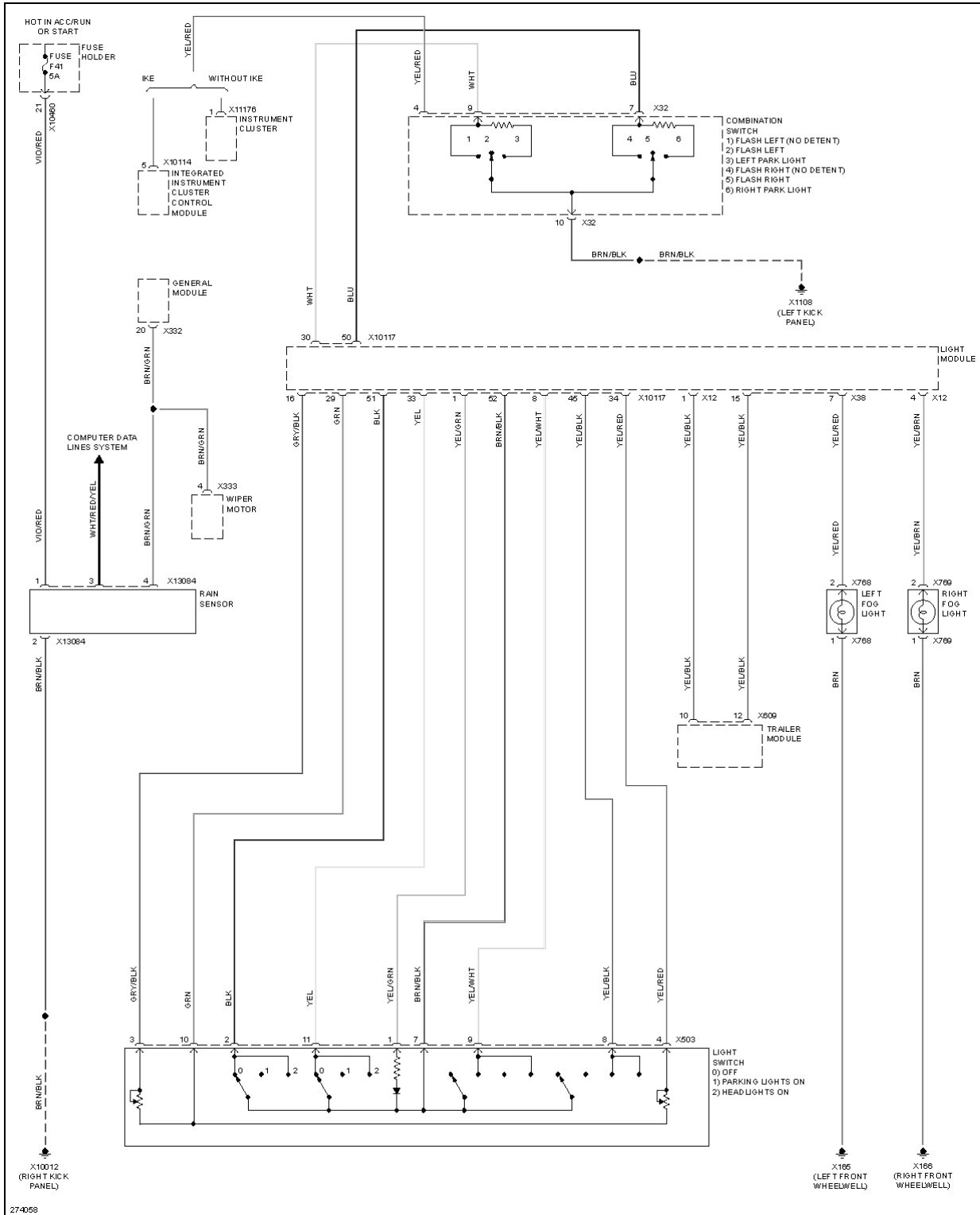

Fig. 53: Adaptive Front Lighting Circuit (1 of 3)

2004 BMW X5 30i

2004 SYSTEM WIRING DIAGRAMS BMW - X5

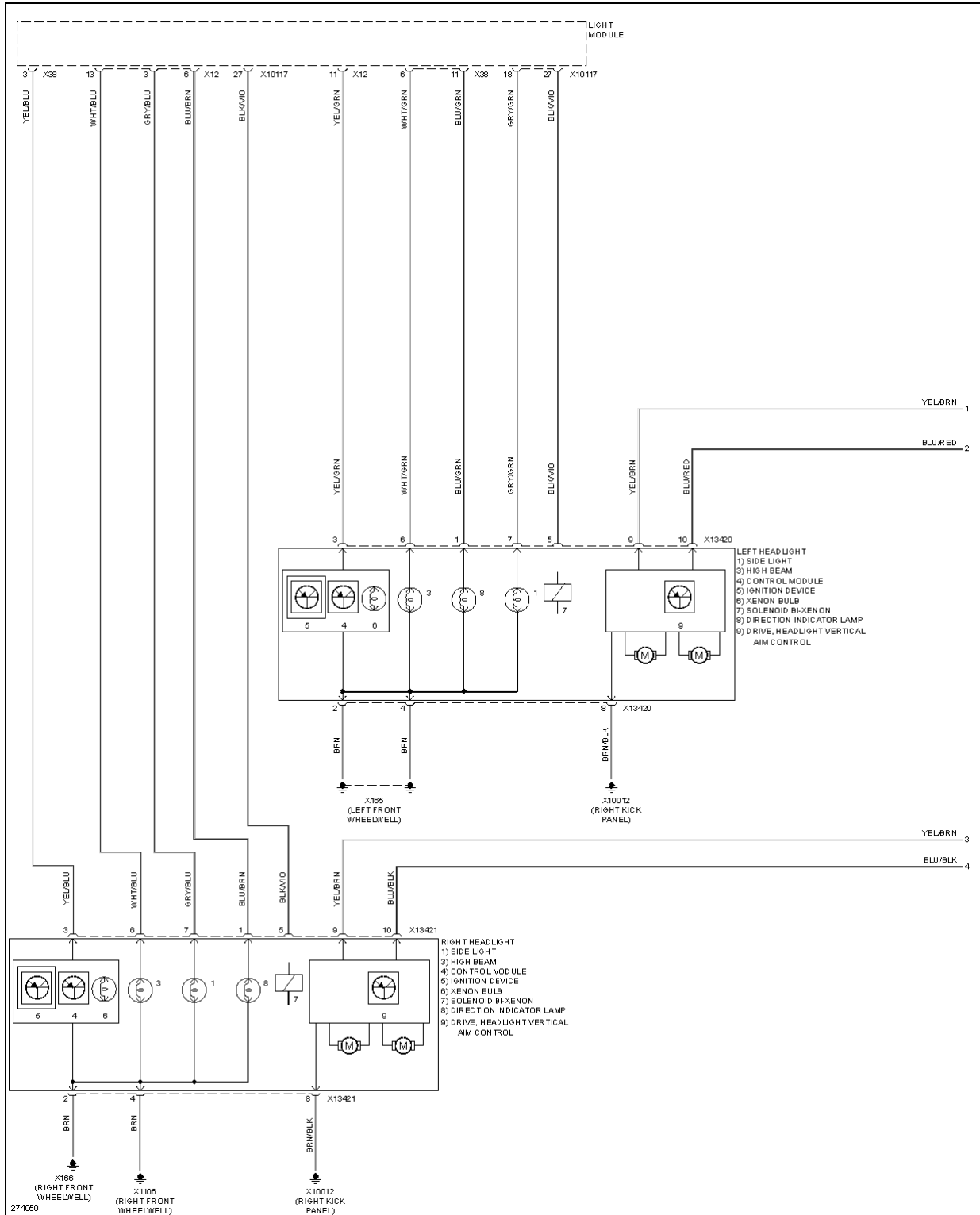

Fig. 54: Adaptive Front Lighting Circuit (2 of 3)

2004 BMW X5 30i

2004 SYSTEM WIRING DIAGRAMS BMW - X5

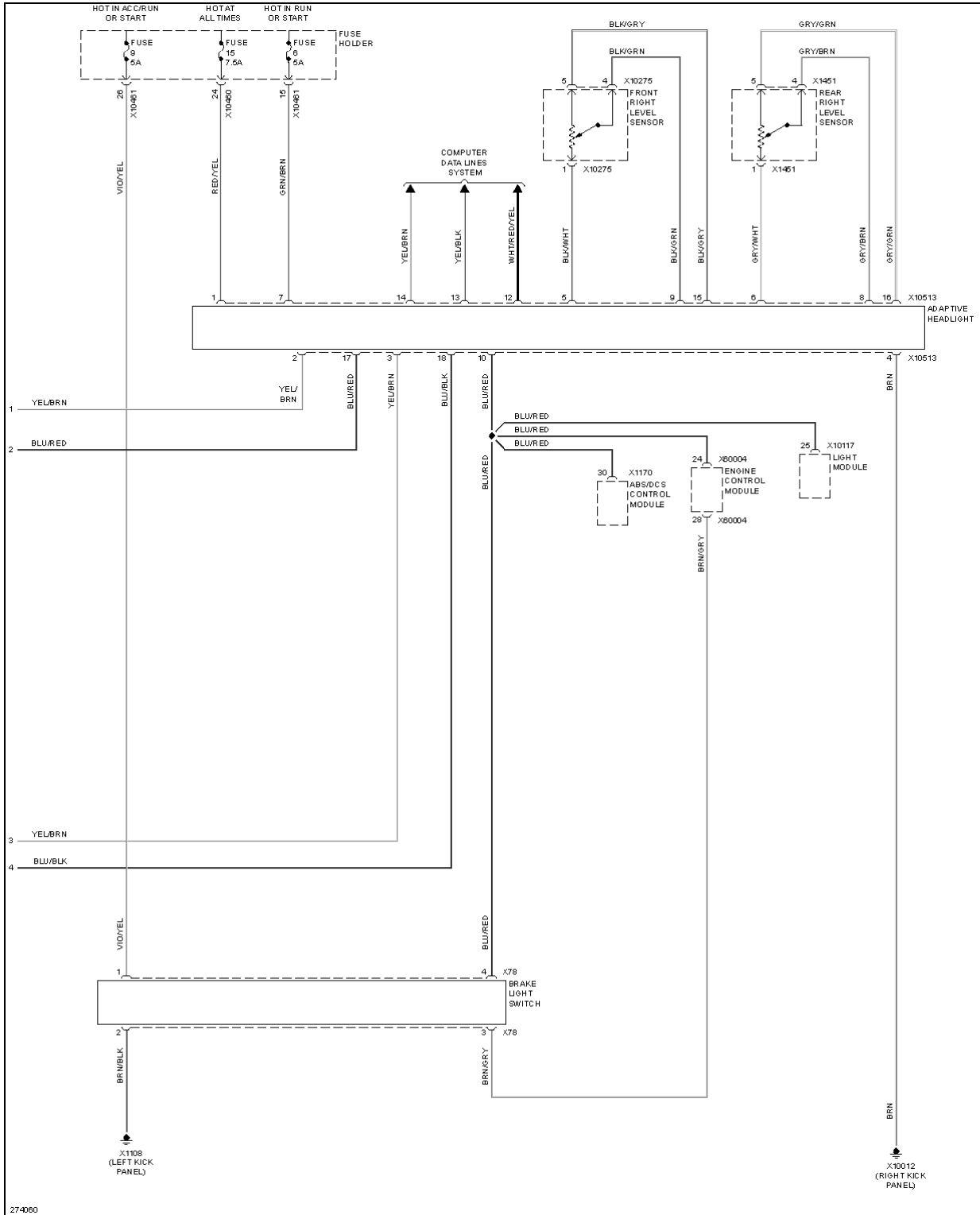

Fig. 55: Adaptive Front Lighting Circuit (3 of 3)

2004 BMW X5 30i

2004 SYSTEM WIRING DIAGRAMS BMW - X5

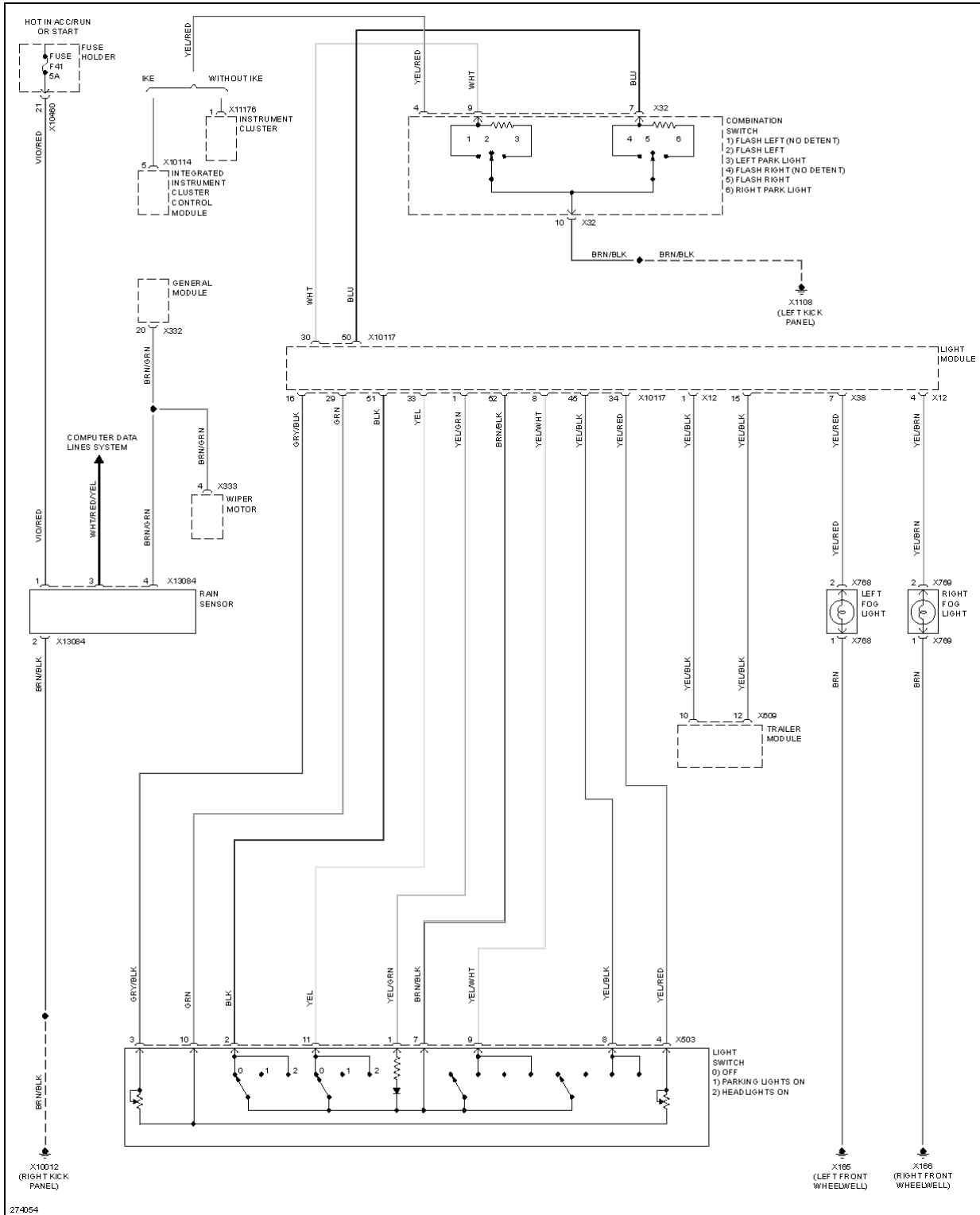

Fig. 56: Headlamps Circuit, W/ Xenon Lamps (1 of 2)

2004 BMW X5 30i

2004 SYSTEM WIRING DIAGRAMS BMW - X5

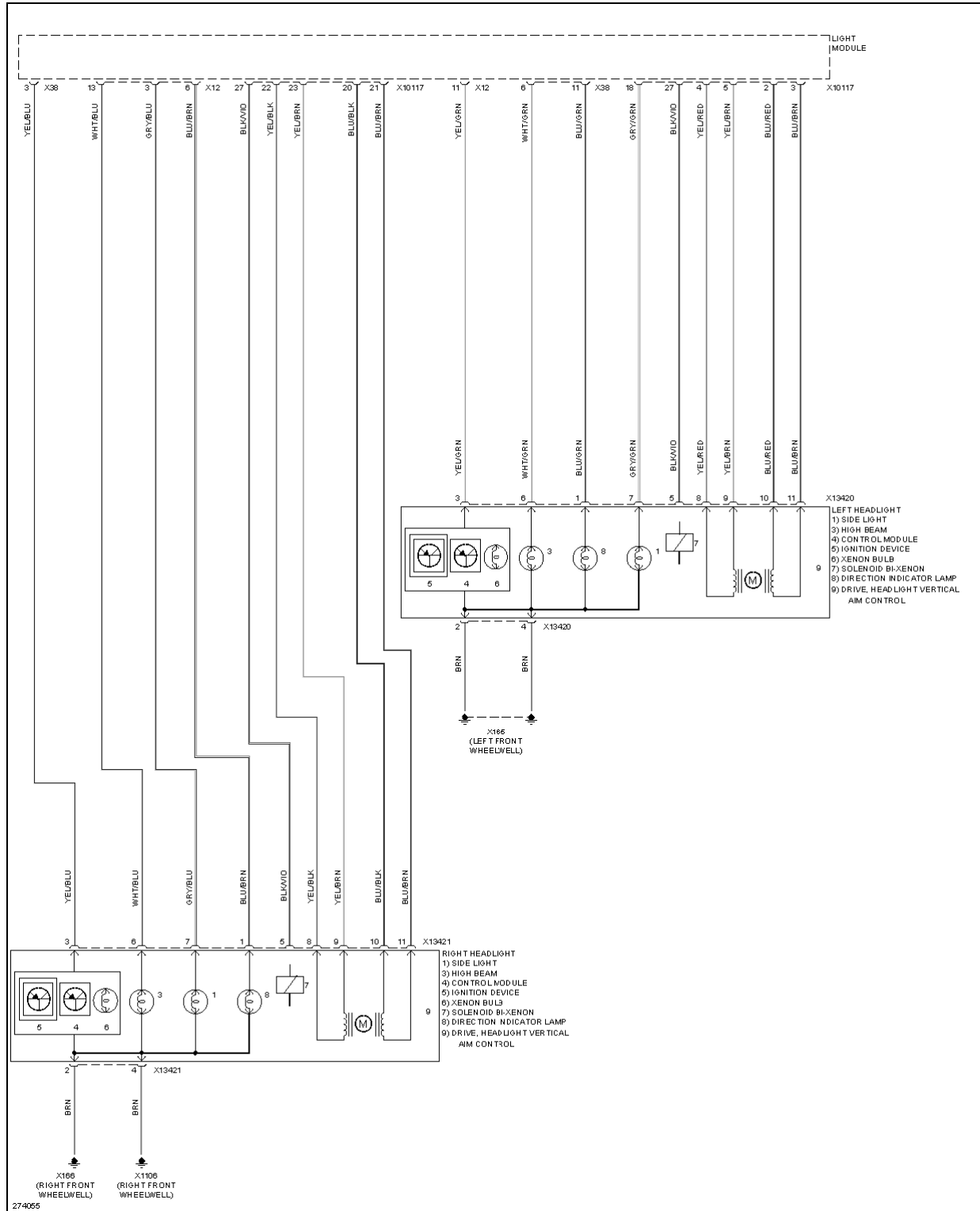

Fig. 57: Headlamps Circuit, W/ Xenon Lamps (2 of 2)

2004 BMW X5 30i

2004 SYSTEM WIRING DIAGRAMS BMW - X5

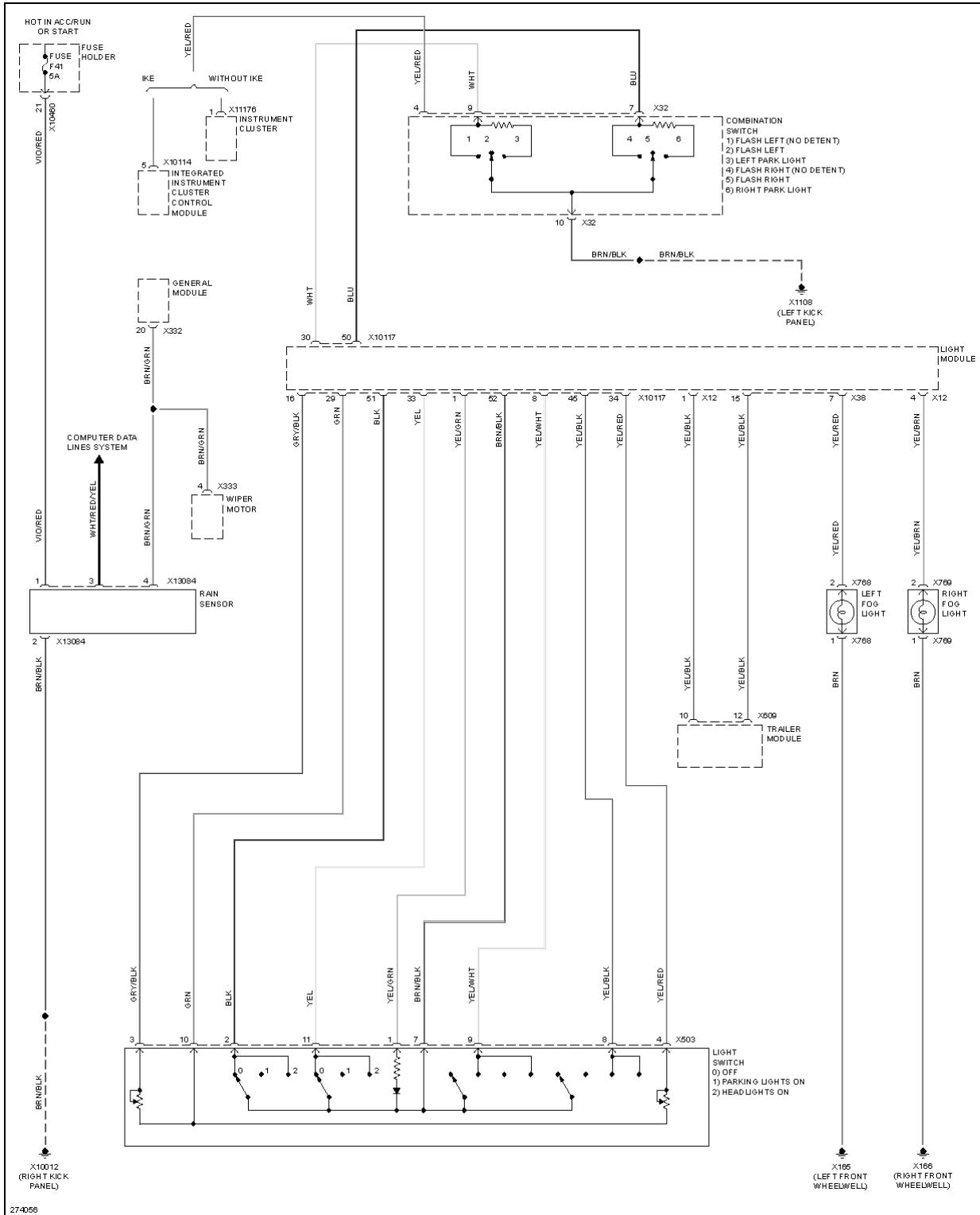

Fig. 58: Headlamps Circuit, W/O Xenon Lamps (1 of 2)

2004 BMW X5 30i

2004 SYSTEM WIRING DIAGRAMS BMW - X5

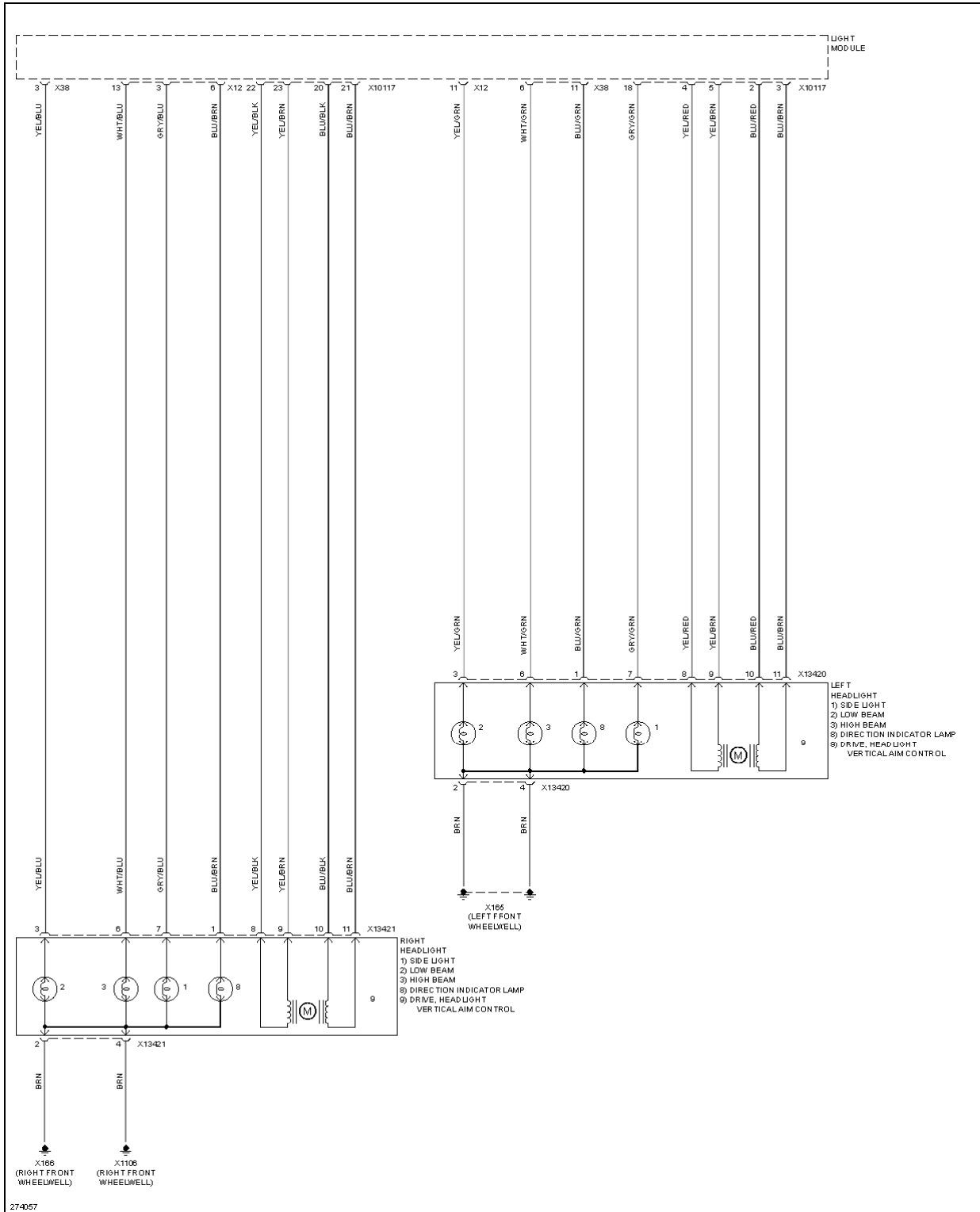

Fig. 59: Headlamps Circuit, W/O Xenon Lamps (2 of 2)

2004 BMW X5 30i

2004 SYSTEM WIRING DIAGRAMS BMW - X5

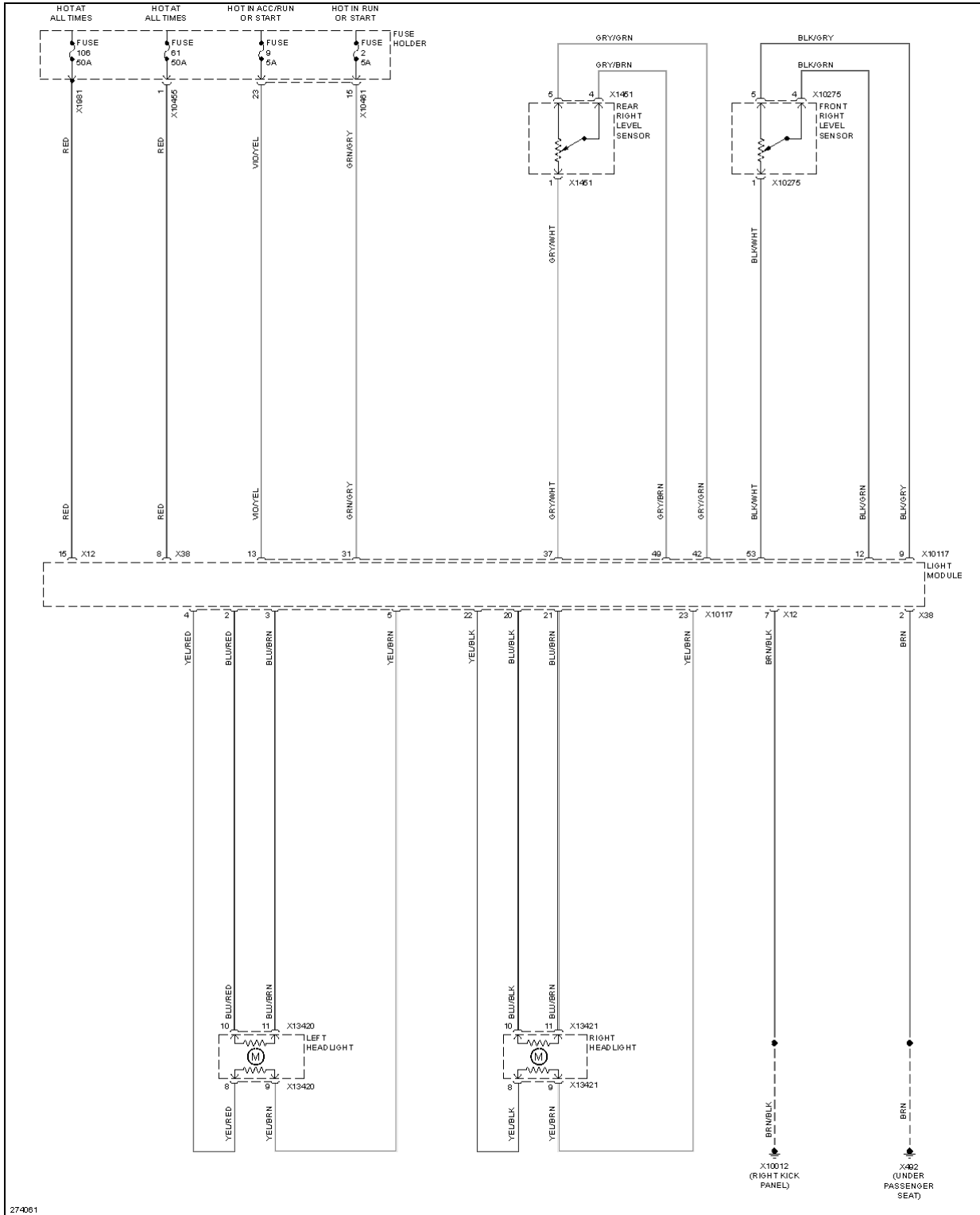

Fig. 60: Headlamps Leveling Circuit

HORN

2004 BMW X5 30i

2004 SYSTEM WIRING DIAGRAMS BMW - X5

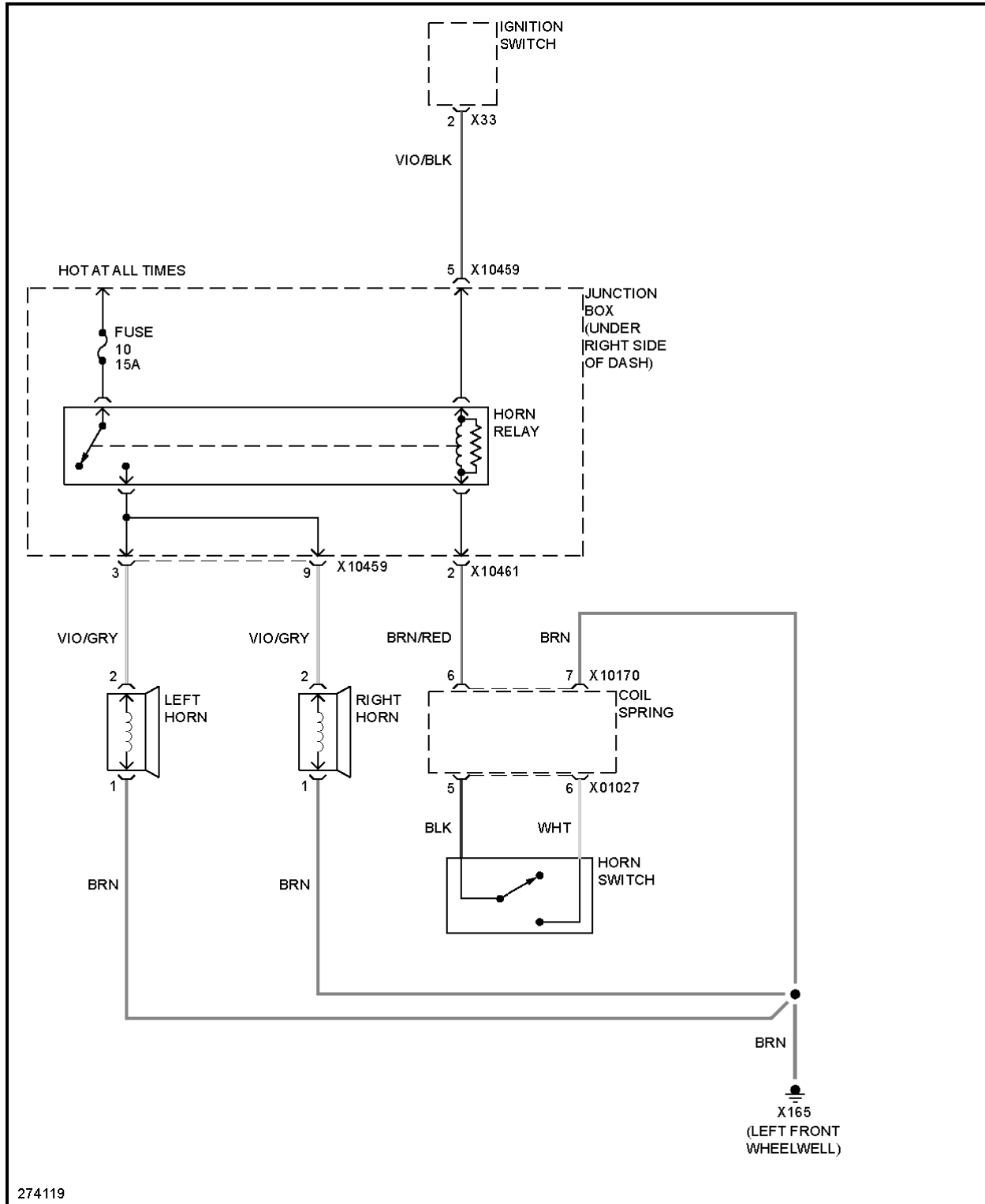

Fig. 61: Horn Circuit

INSTRUMENT CLUSTER

3.0L

2004 BMW X5 30i

2004 SYSTEM WIRING DIAGRAMS BMW - X5

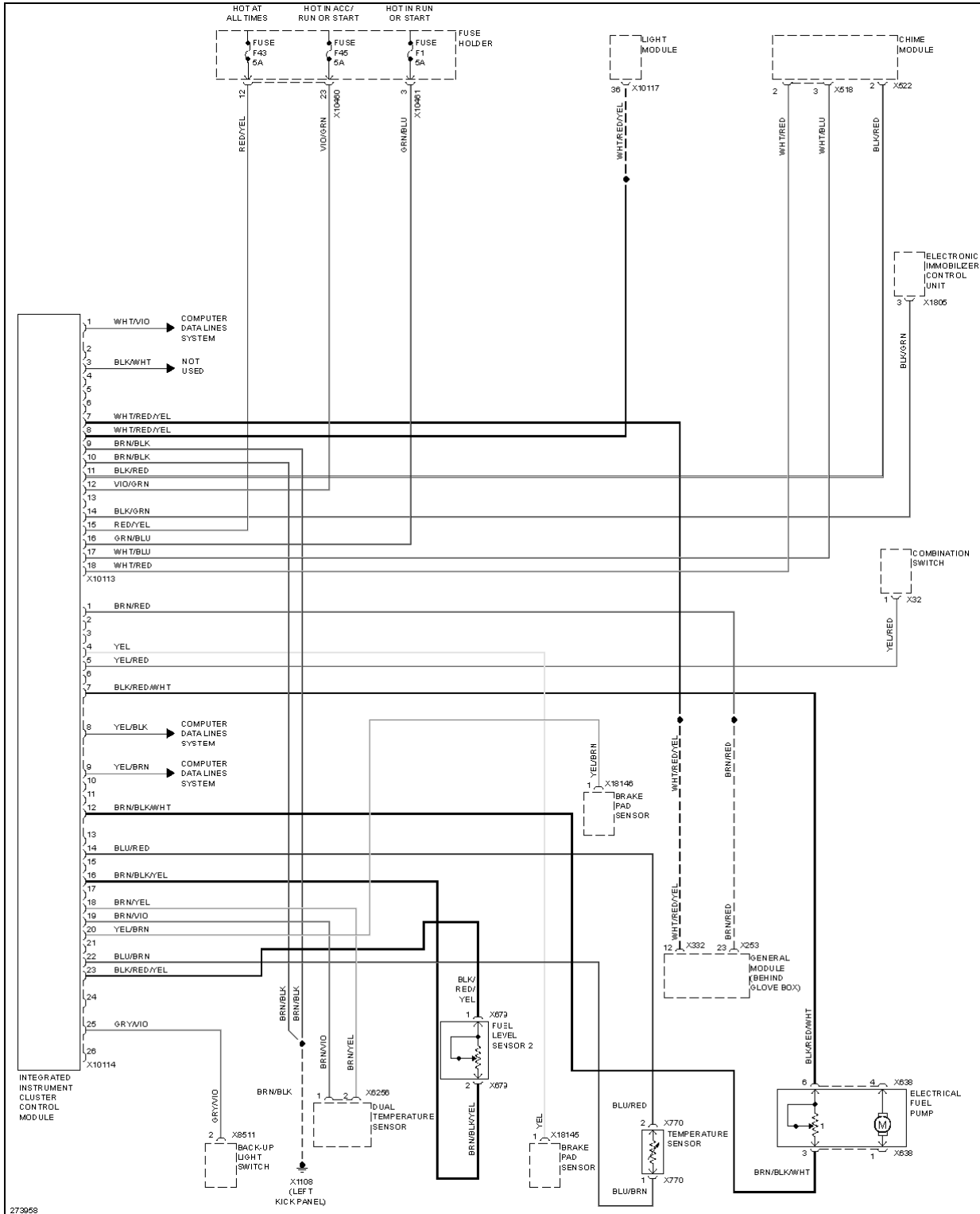

Fig. 62: 3.0L, Instrument Cluster Circuit, W/ IKE (1 of 2)

2004 BMW X5 30i

2004 SYSTEM WIRING DIAGRAMS BMW - X5

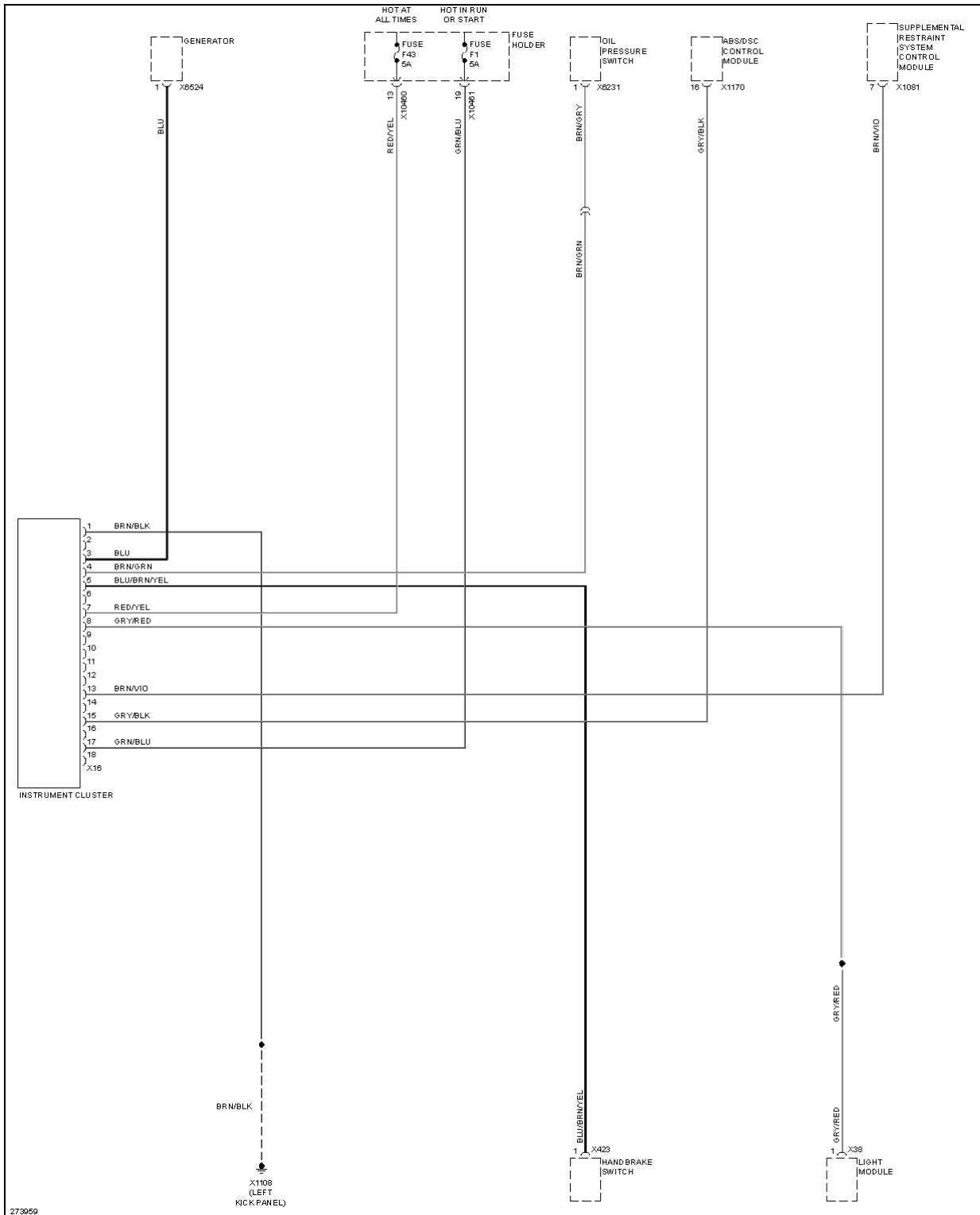

Fig. 63: 3.0L, Instrument Cluster Circuit, W/ IKE (2 of 2)

2004 BMW X5 30i

2004 SYSTEM WIRING DIAGRAMS BMW - X5

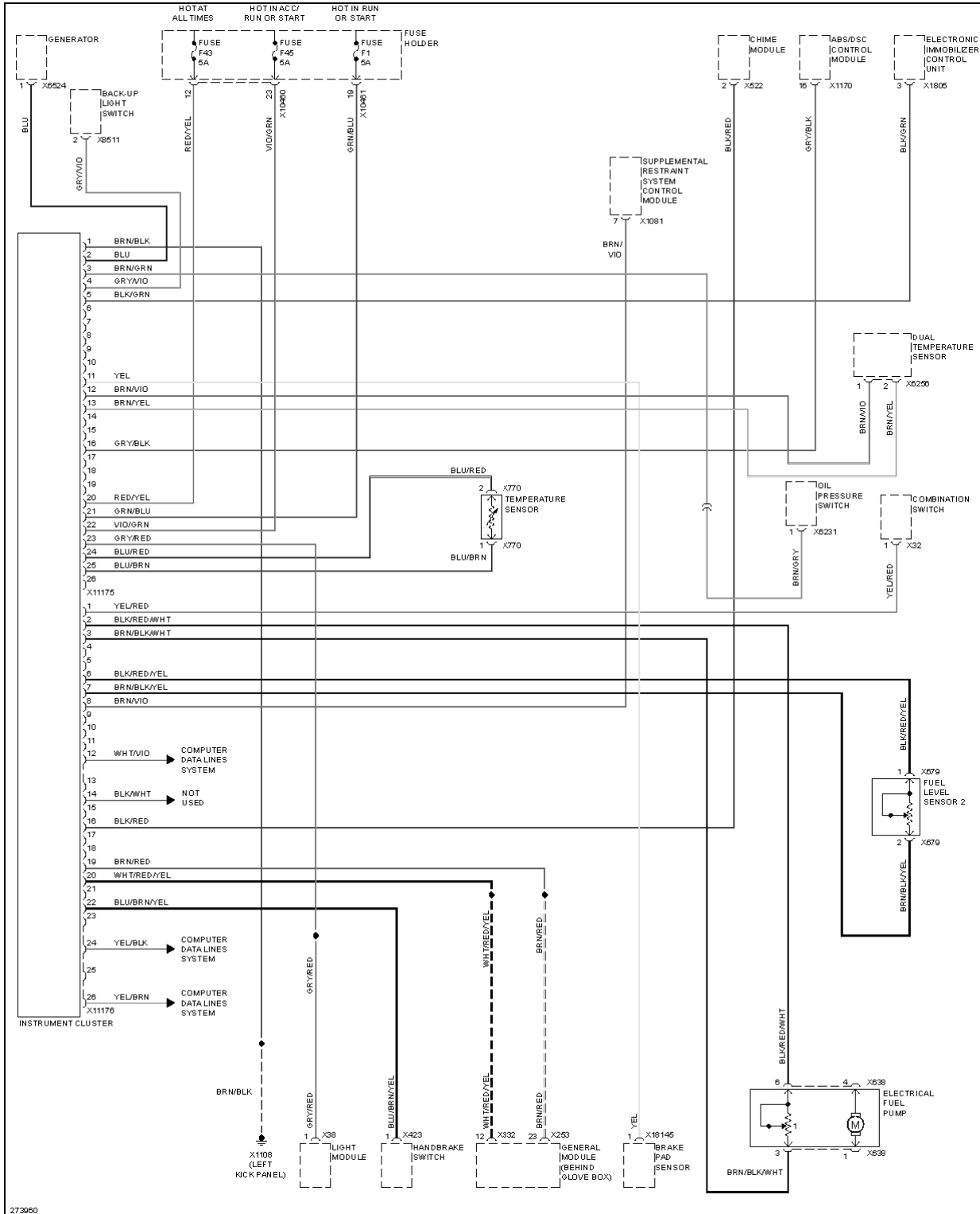

Fig. 64: 3.0L, Instrument Cluster Circuit, W/O IKE

4.4L

2004 BMW X5 30i

2004 SYSTEM WIRING DIAGRAMS BMW - X5

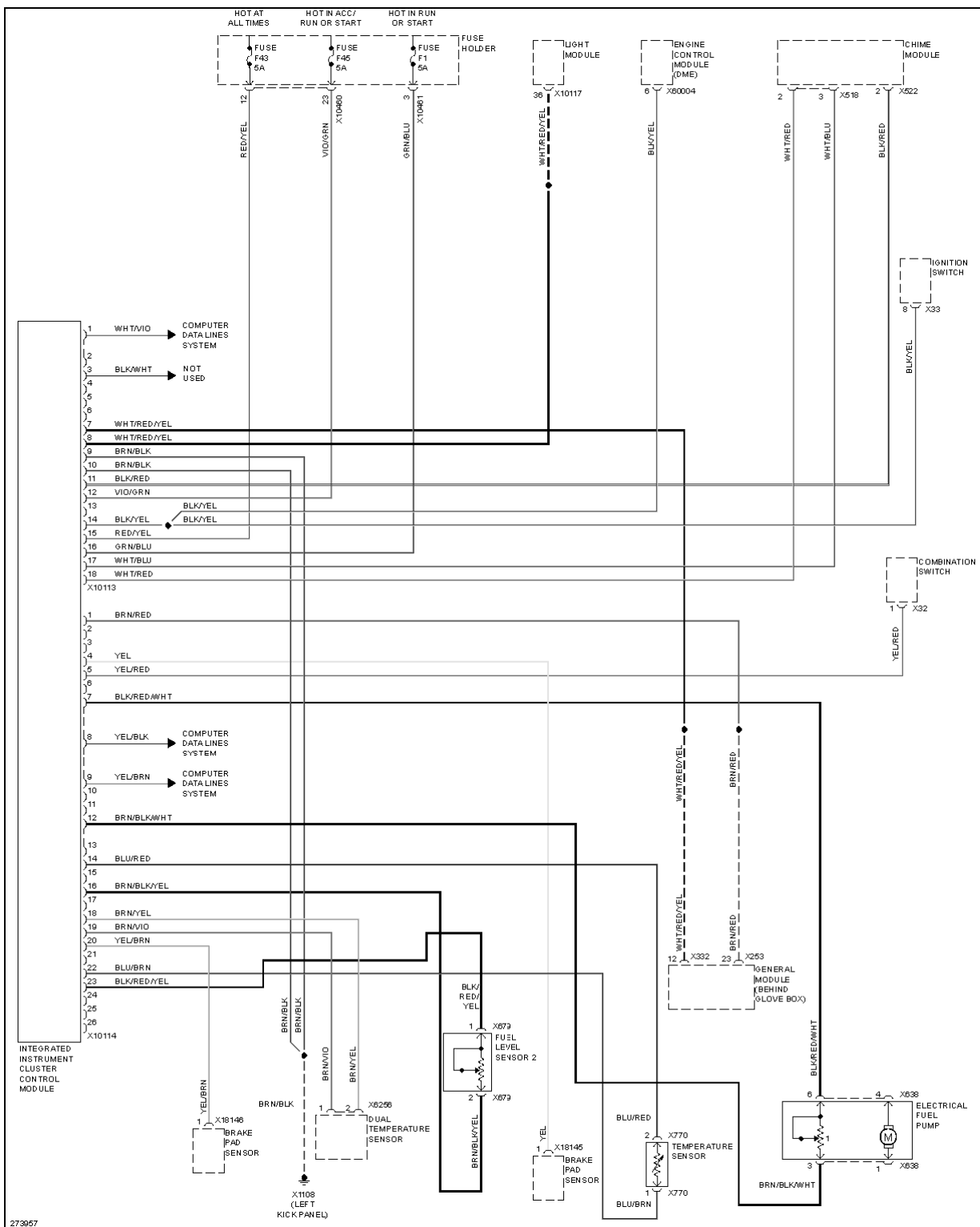

Fig. 65: 4.4L, Instrument Cluster Circuit, W/ IKE

2004 BMW X5 30i

2004 SYSTEM WIRING DIAGRAMS BMW - X5

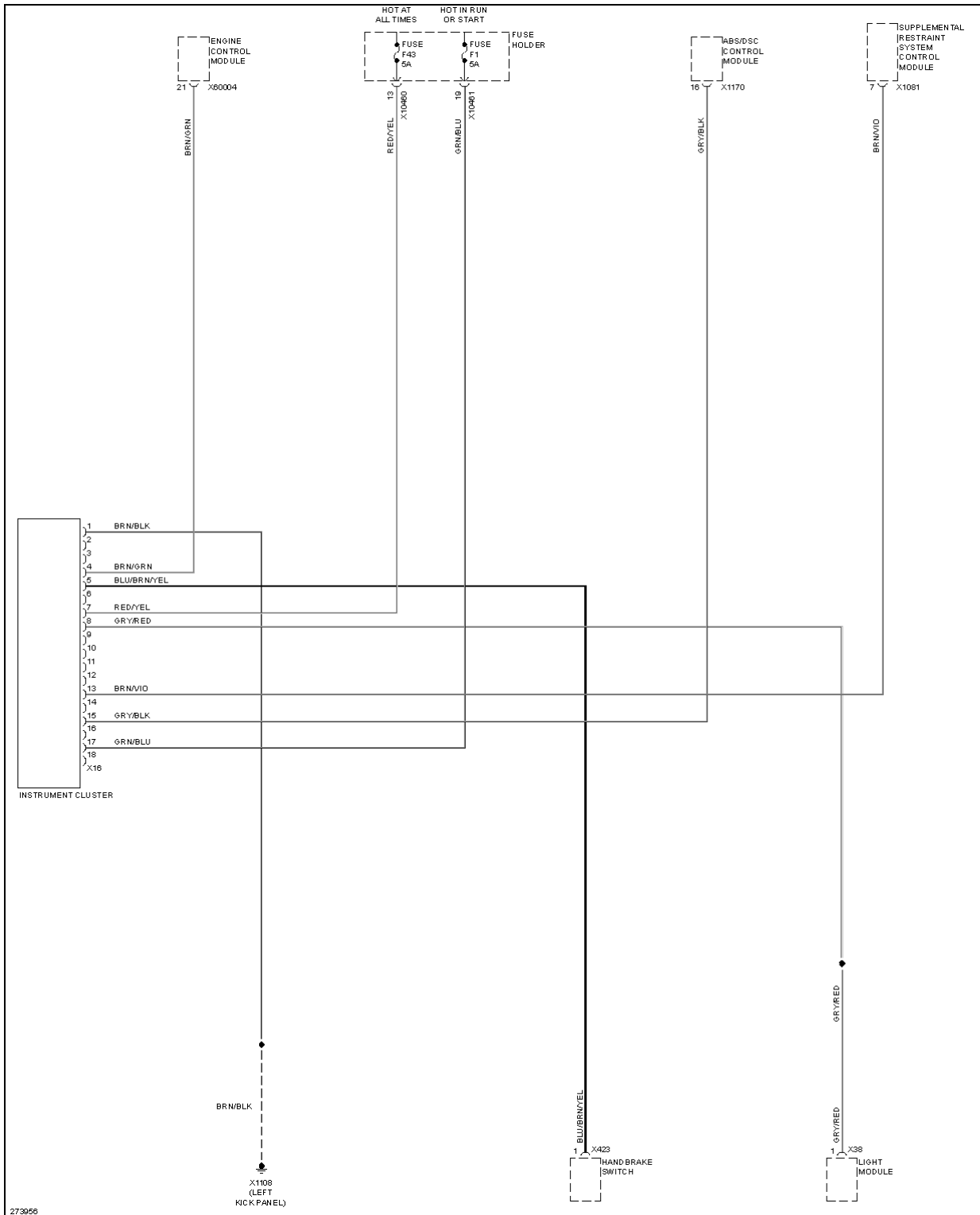

Fig. 66: 4.4L, Instrument Cluster Circuit, W/O IKE

4.8L

2004 BMW X5 30i

2004 SYSTEM WIRING DIAGRAMS BMW - X5

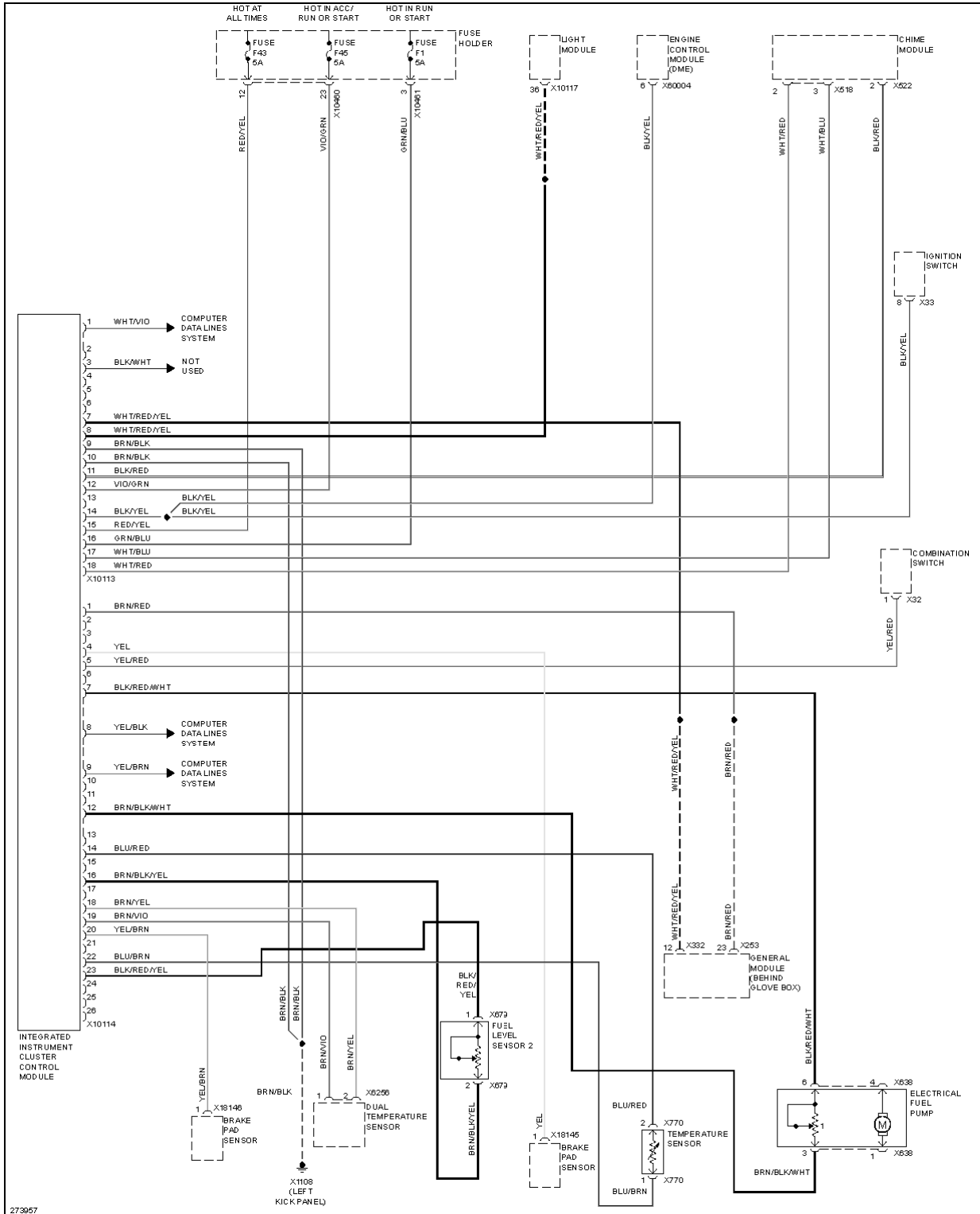

Fig. 67: 4.8L, Instrument Cluster Circuit, W/ IKE

2004 BMW X5 30i

2004 SYSTEM WIRING DIAGRAMS BMW - X5

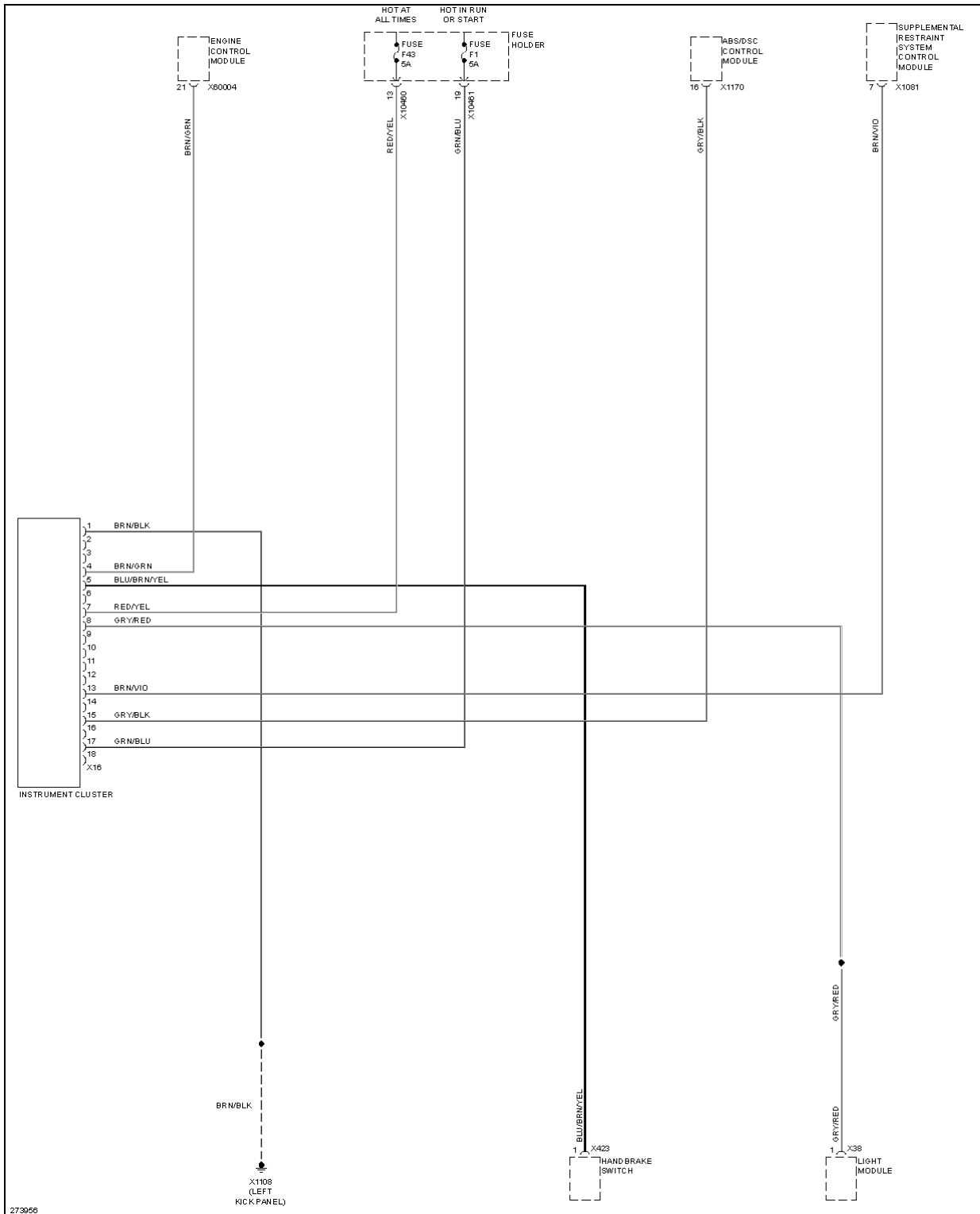

Fig. 68: 4.8L, Instrument Cluster Circuit, W/O IKE

INTERIOR LIGHTS

2004 BMW X5 30i

2004 SYSTEM WIRING DIAGRAMS BMW - X5

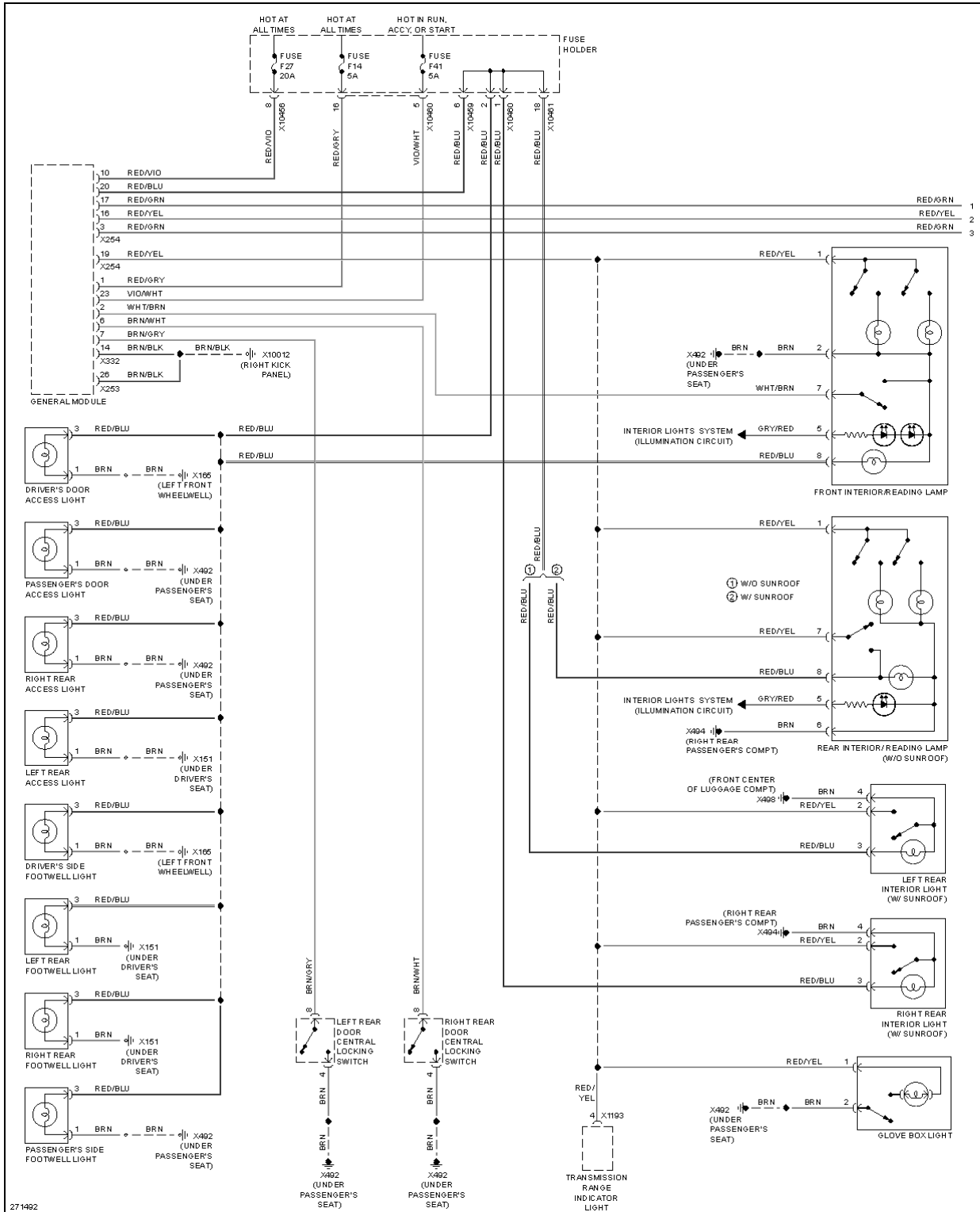

Fig. 69: Courtesy Lamps Circuit (1 of 2)

2004 BMW X5 30i

2004 SYSTEM WIRING DIAGRAMS BMW - X5

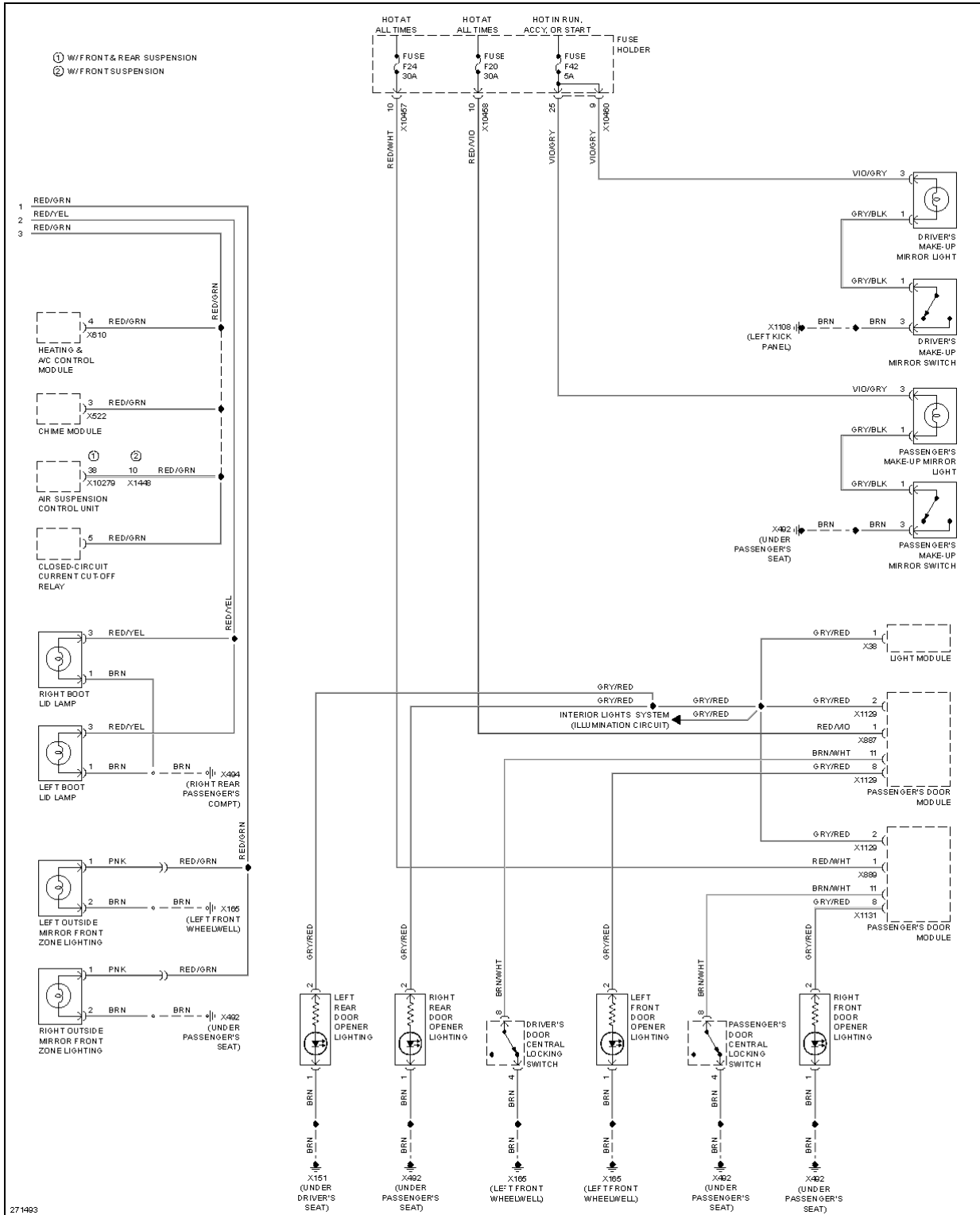

Fig. 70: Courtesy Lamps Circuit (2 of 2)

2004 BMW X5 30i

2004 SYSTEM WIRING DIAGRAMS BMW - X5

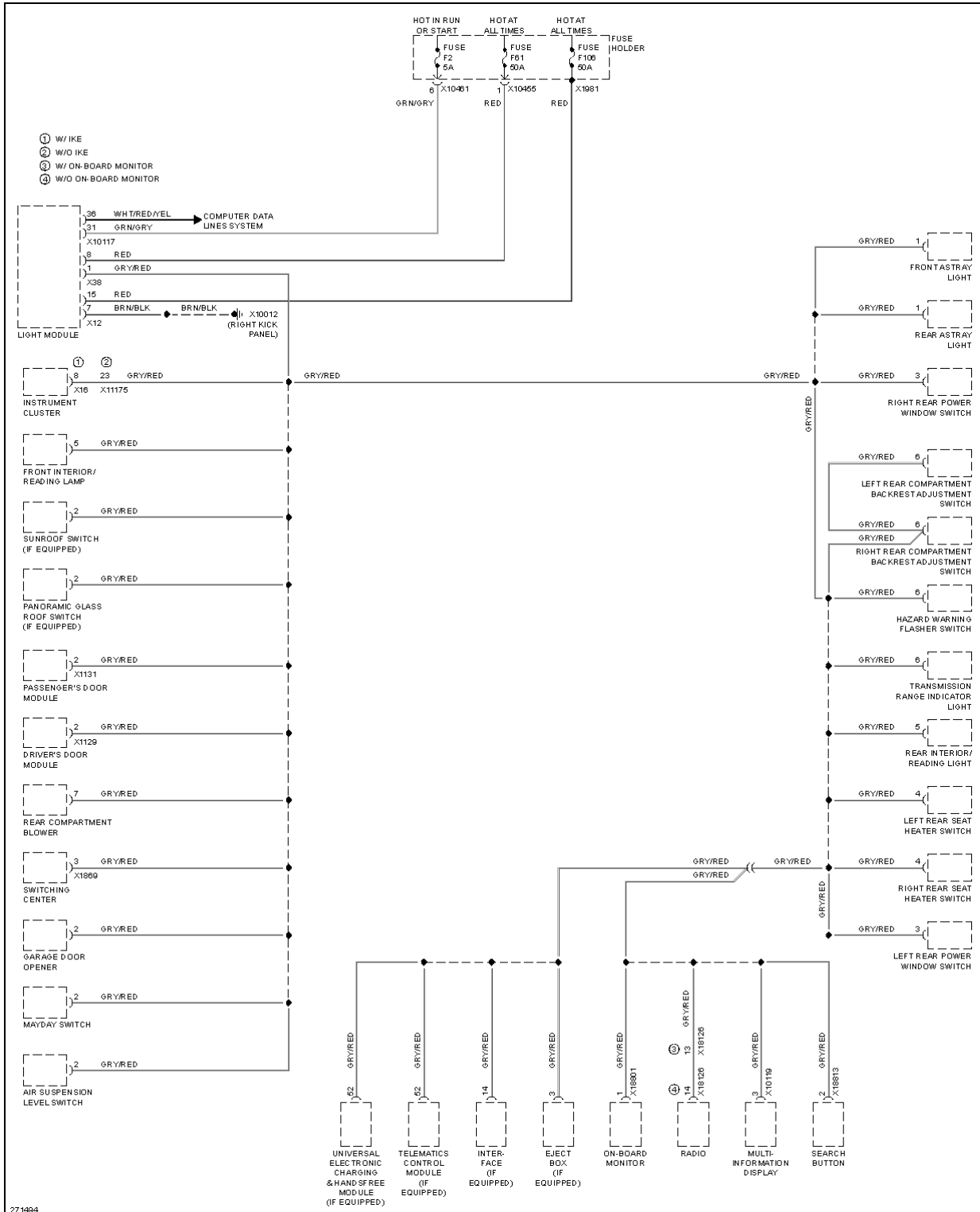

Fig. 71: Instrument Illumination Circuit

MEMORY SYSTEMS

2004 BMW X5 30i

2004 SYSTEM WIRING DIAGRAMS BMW - X5

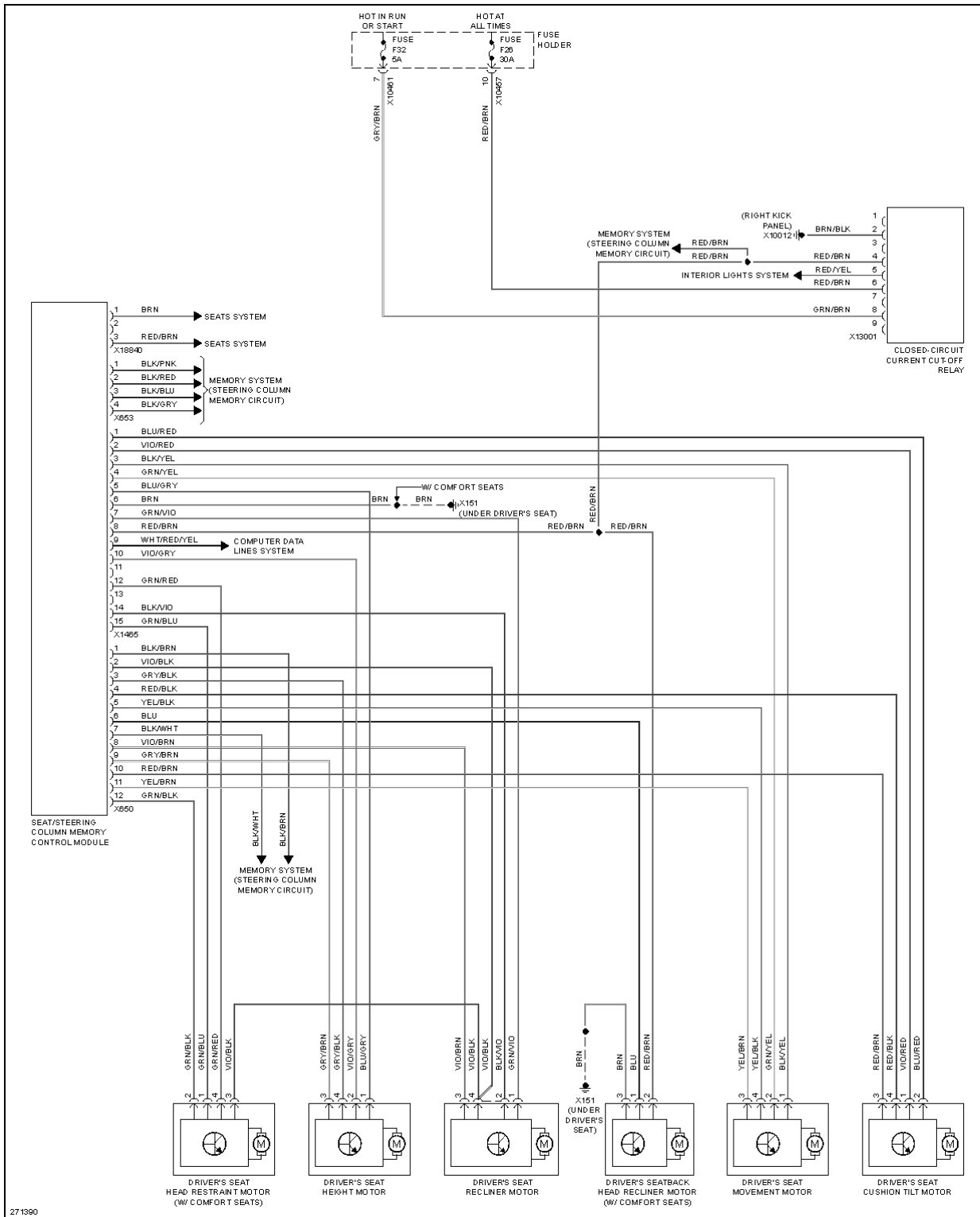

Fig. 72: Driver's Memory Seat Circuit

2004 BMW X5 30i

2004 SYSTEM WIRING DIAGRAMS BMW - X5

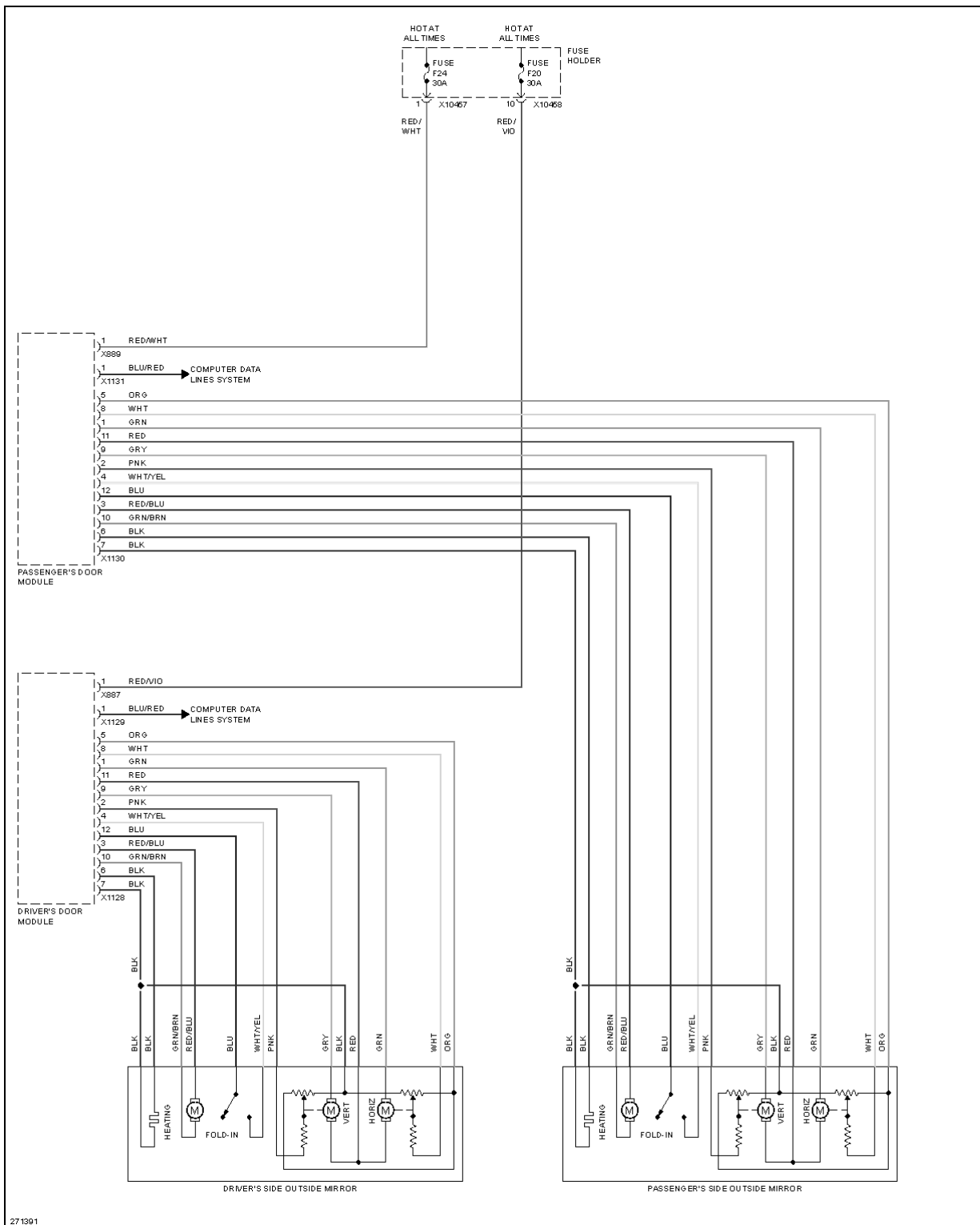

Fig. 73: Memory Mirrors Circuit

2004 BMW X5 30i

2004 SYSTEM WIRING DIAGRAMS BMW - X5

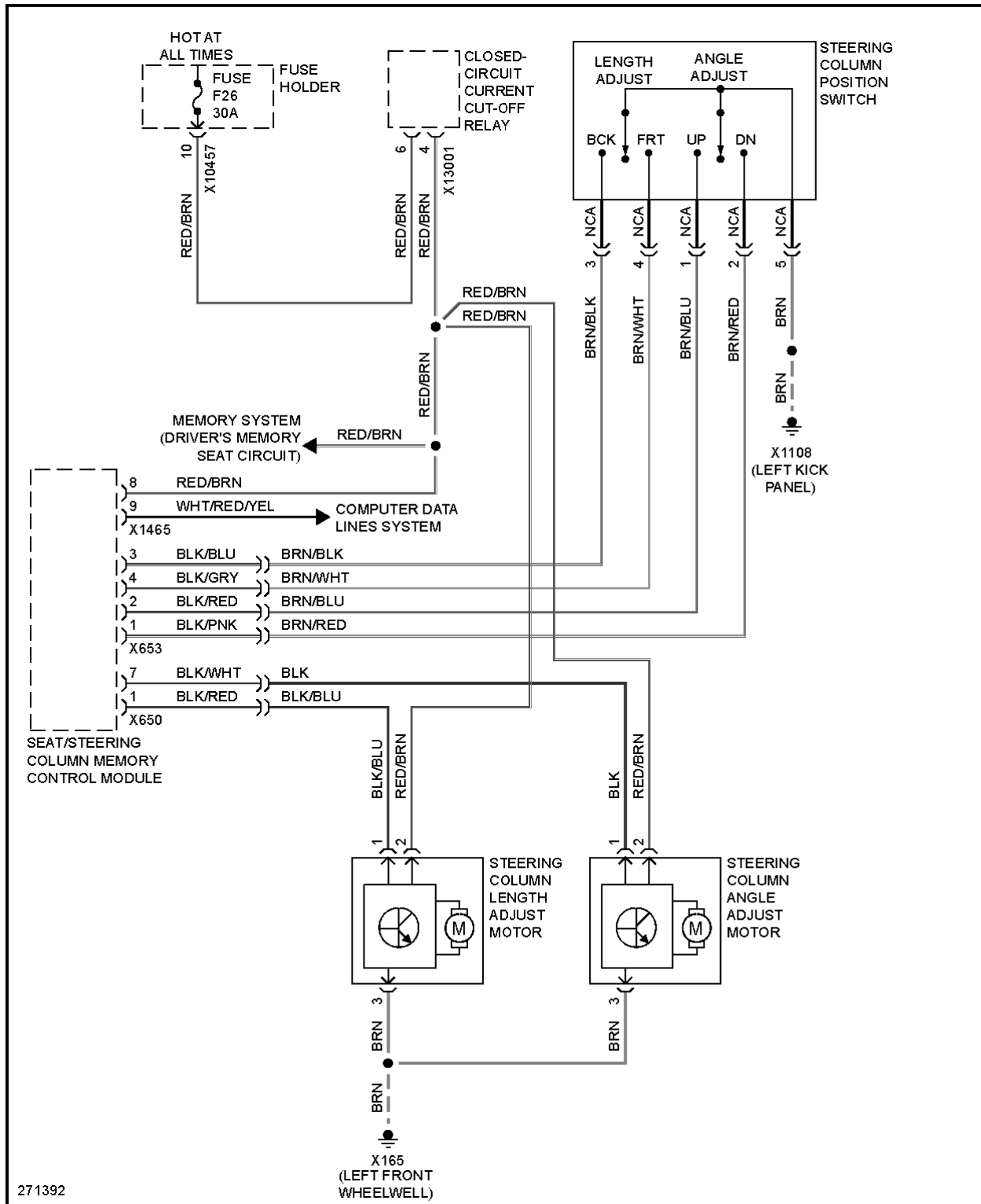

Fig. 74: Steering Column Memory Circuit

NAVIGATION

2004 BMW X5 30i

2004 SYSTEM WIRING DIAGRAMS BMW - X5

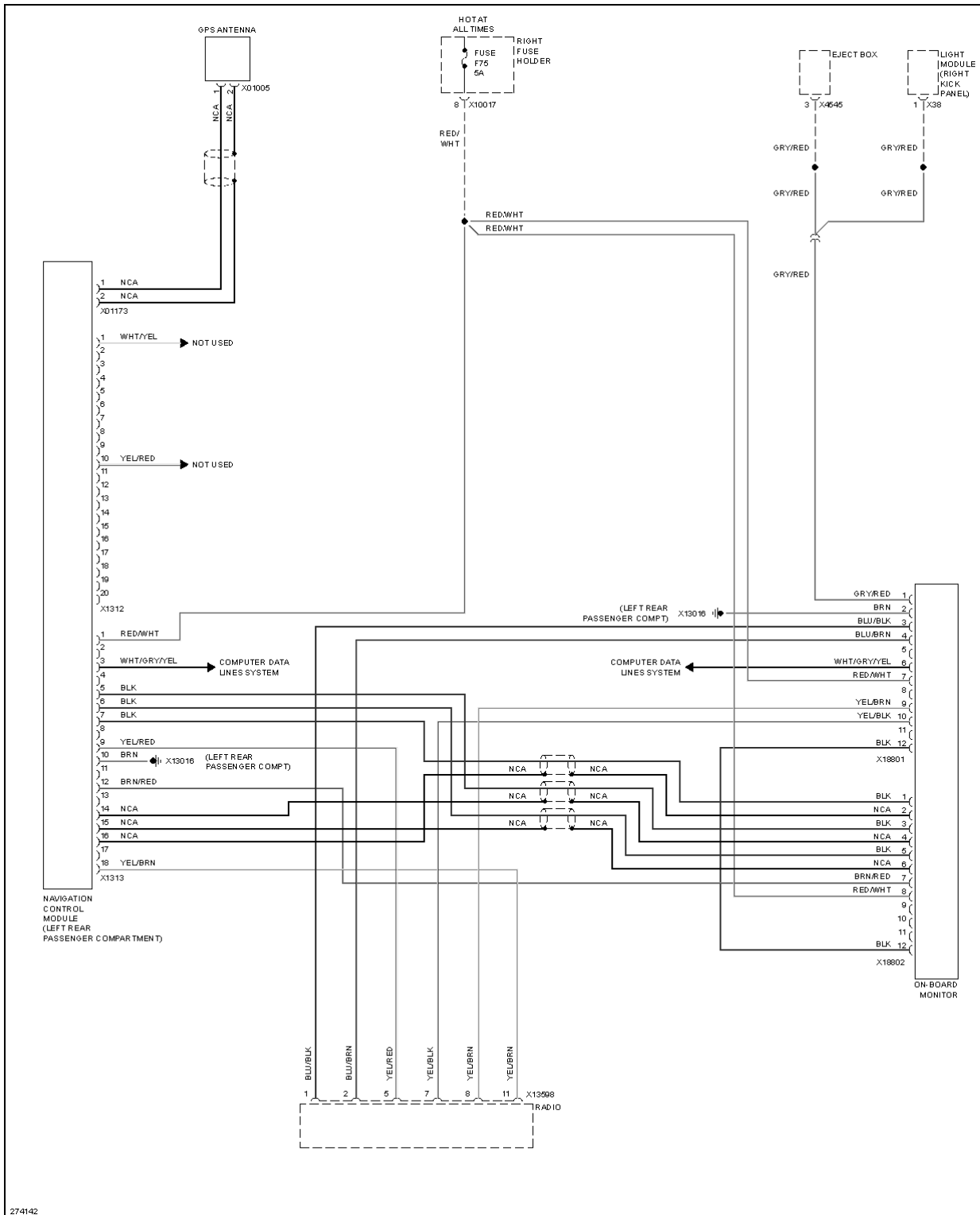

Fig. 75: Navigation Circuit

2004 BMW X5 30i

2004 SYSTEM WIRING DIAGRAMS BMW - X5

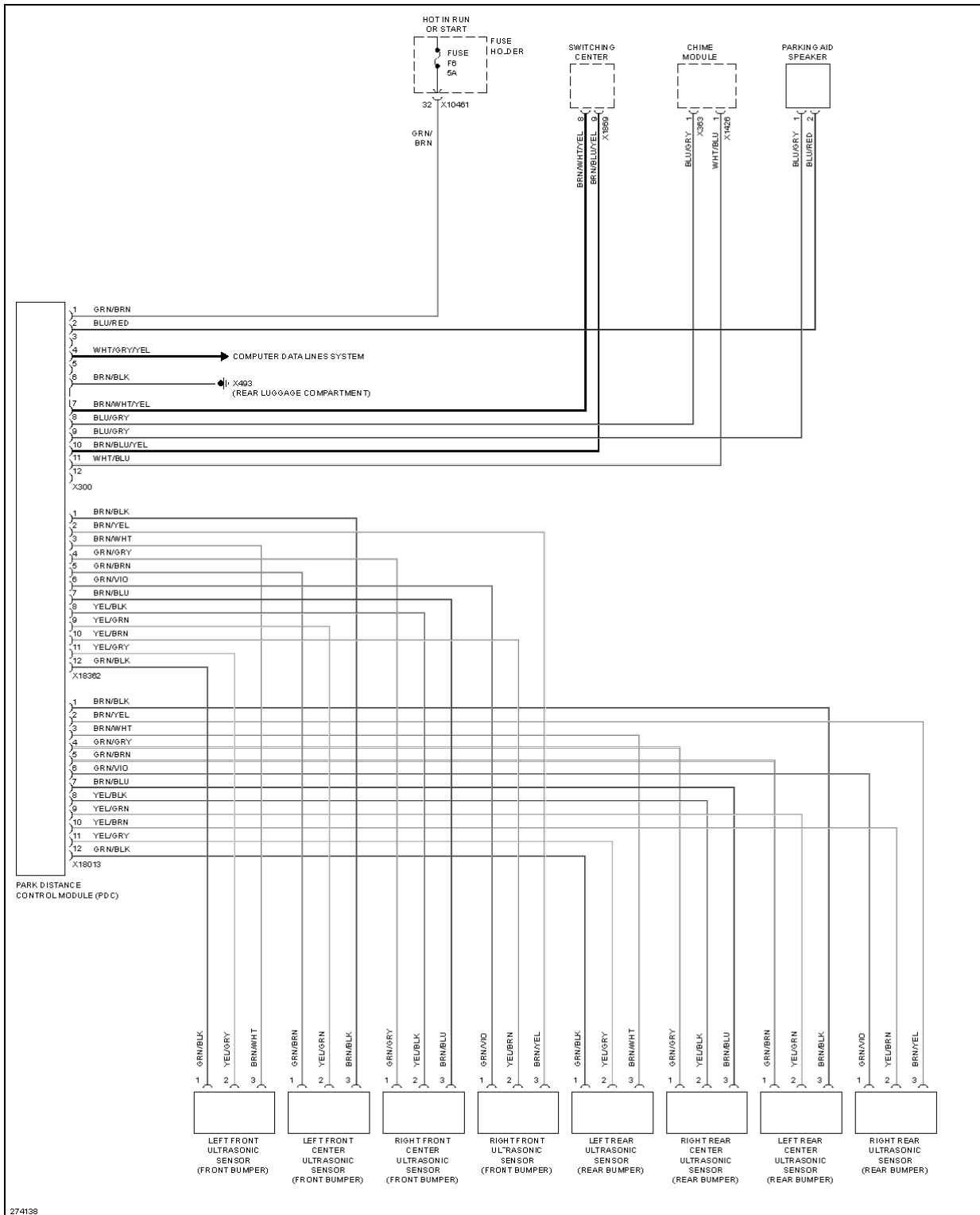

Fig. 76: Parking Assistant Circuit

POWER DISTRIBUTION

3.0L

2004 BMW X5 30i

2004 SYSTEM WIRING DIAGRAMS BMW - X5

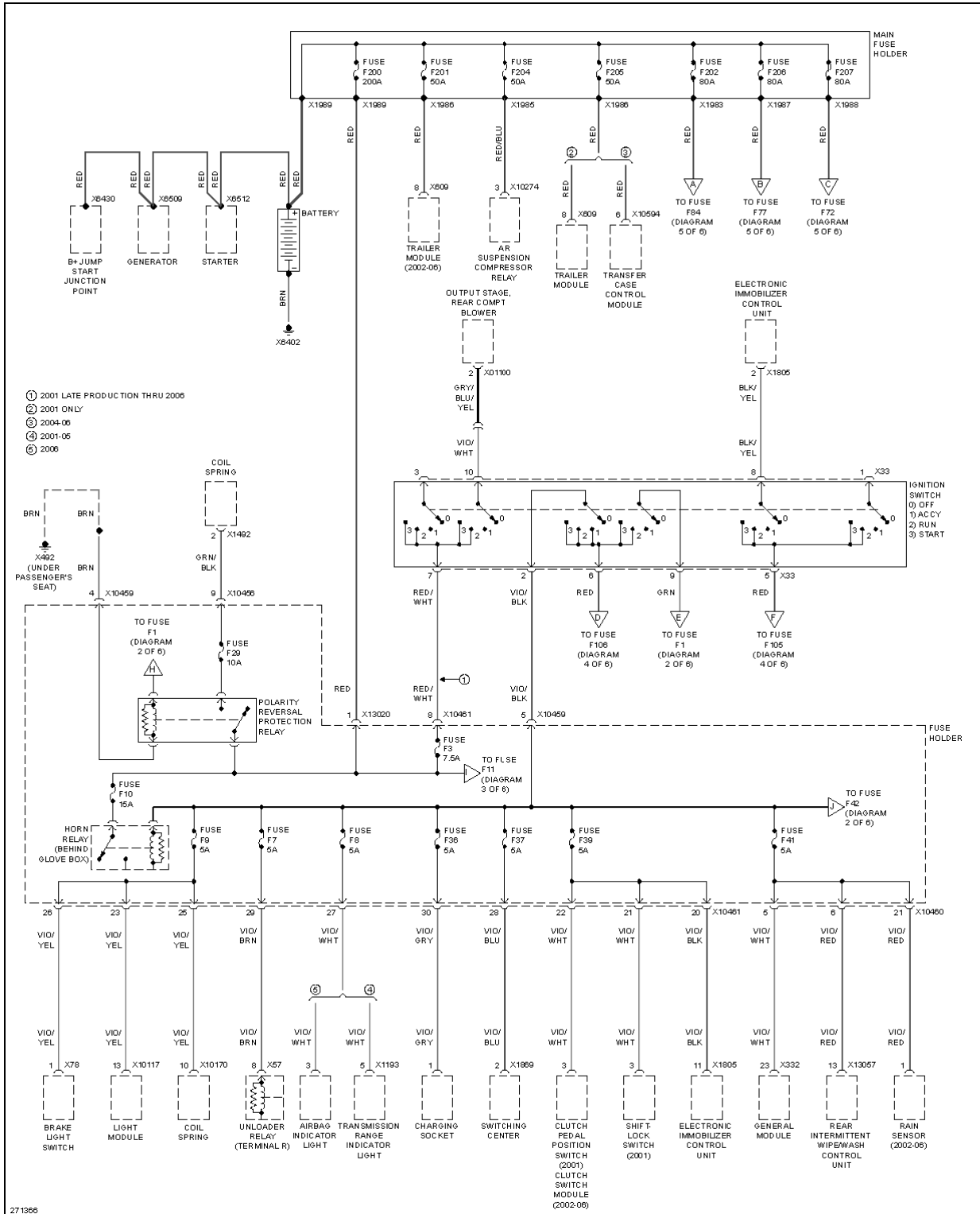

Fig. 77: 3.0L, Power Distribution Circuit (1 of 6)

2004 BMW X5 30i

2004 SYSTEM WIRING DIAGRAMS BMW - X5

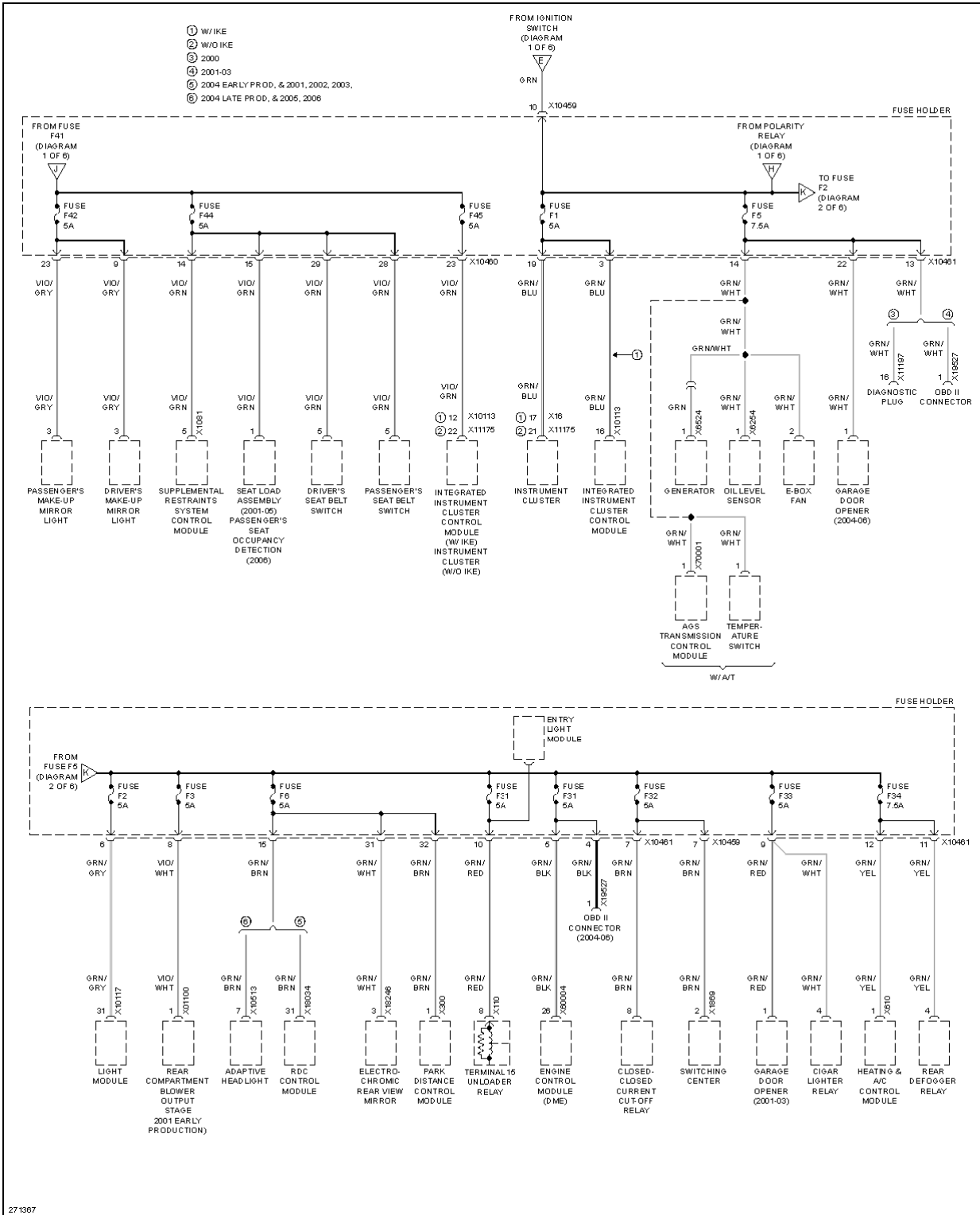

Fig. 78: 3.0L, Power Distribution Circuit (2 of 6)

2004 BMW X5 30i

2004 SYSTEM WIRING DIAGRAMS BMW - X5

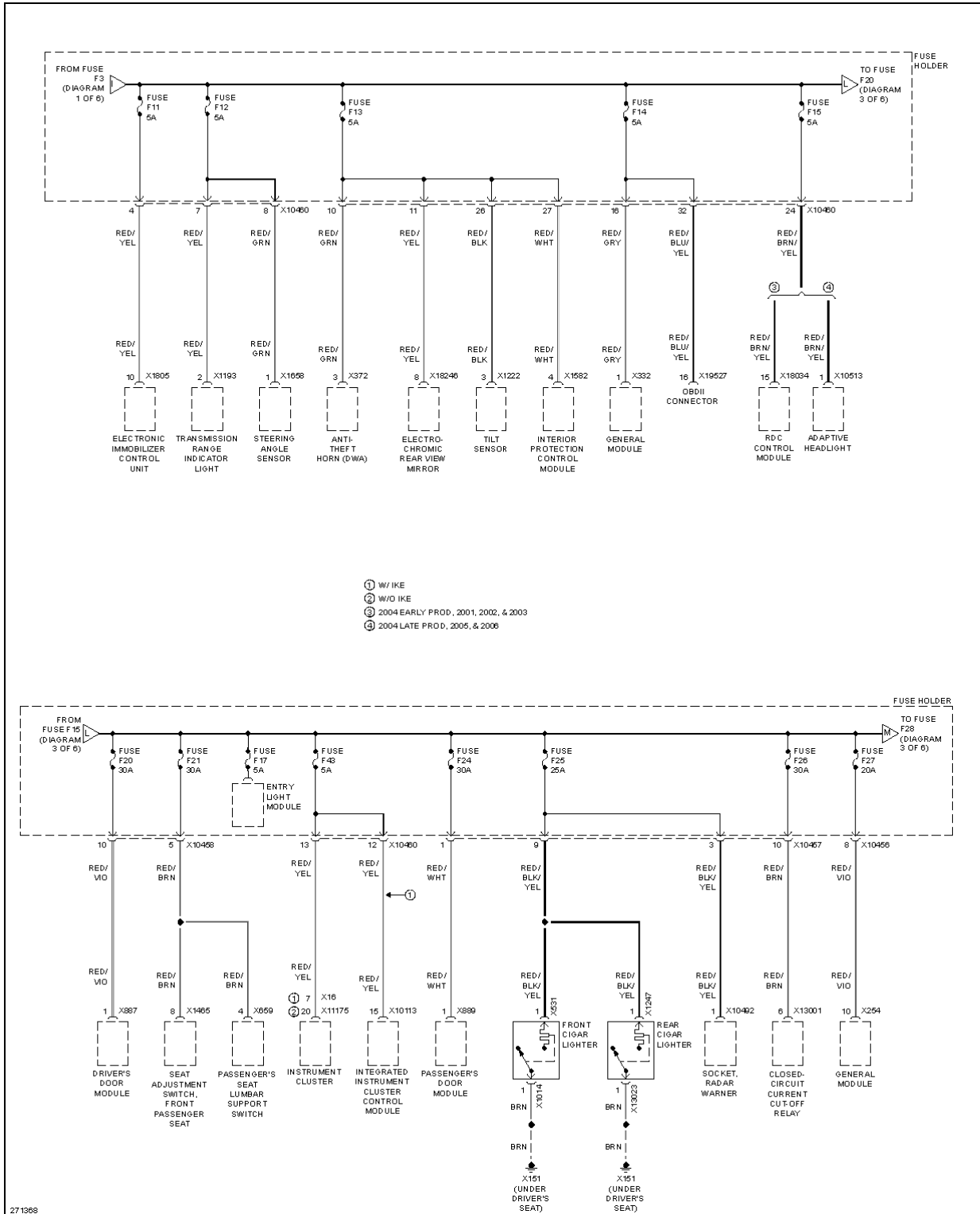

Fig. 79: 3.0L, Power Distribution Circuit (3 of 6)

2004 BMW X5 30i

2004 SYSTEM WIRING DIAGRAMS BMW - X5

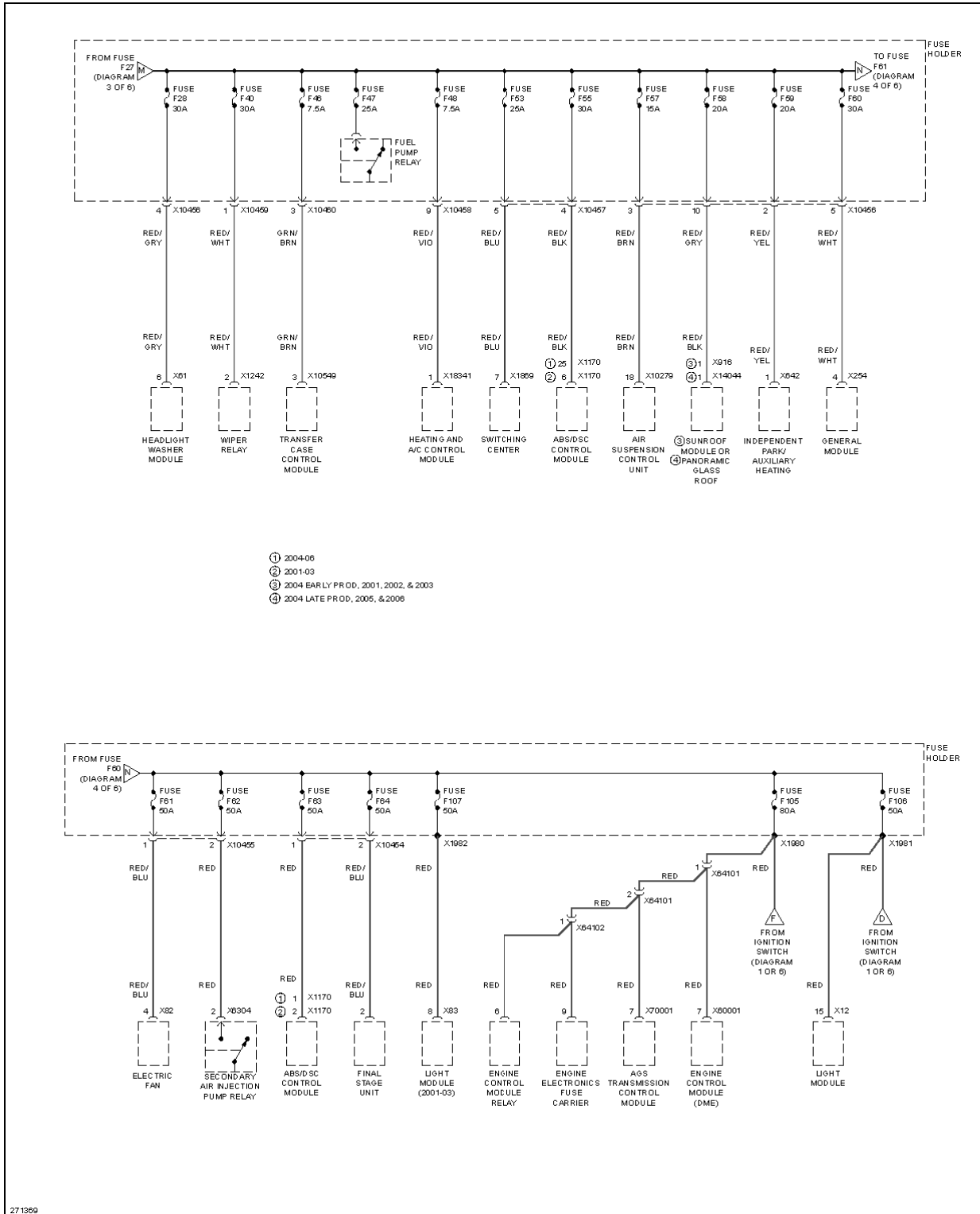

Fig. 80: 3.0L, Power Distribution Circuit (4 of 6)

2004 BMW X5 30i

2004 SYSTEM WIRING DIAGRAMS BMW - X5

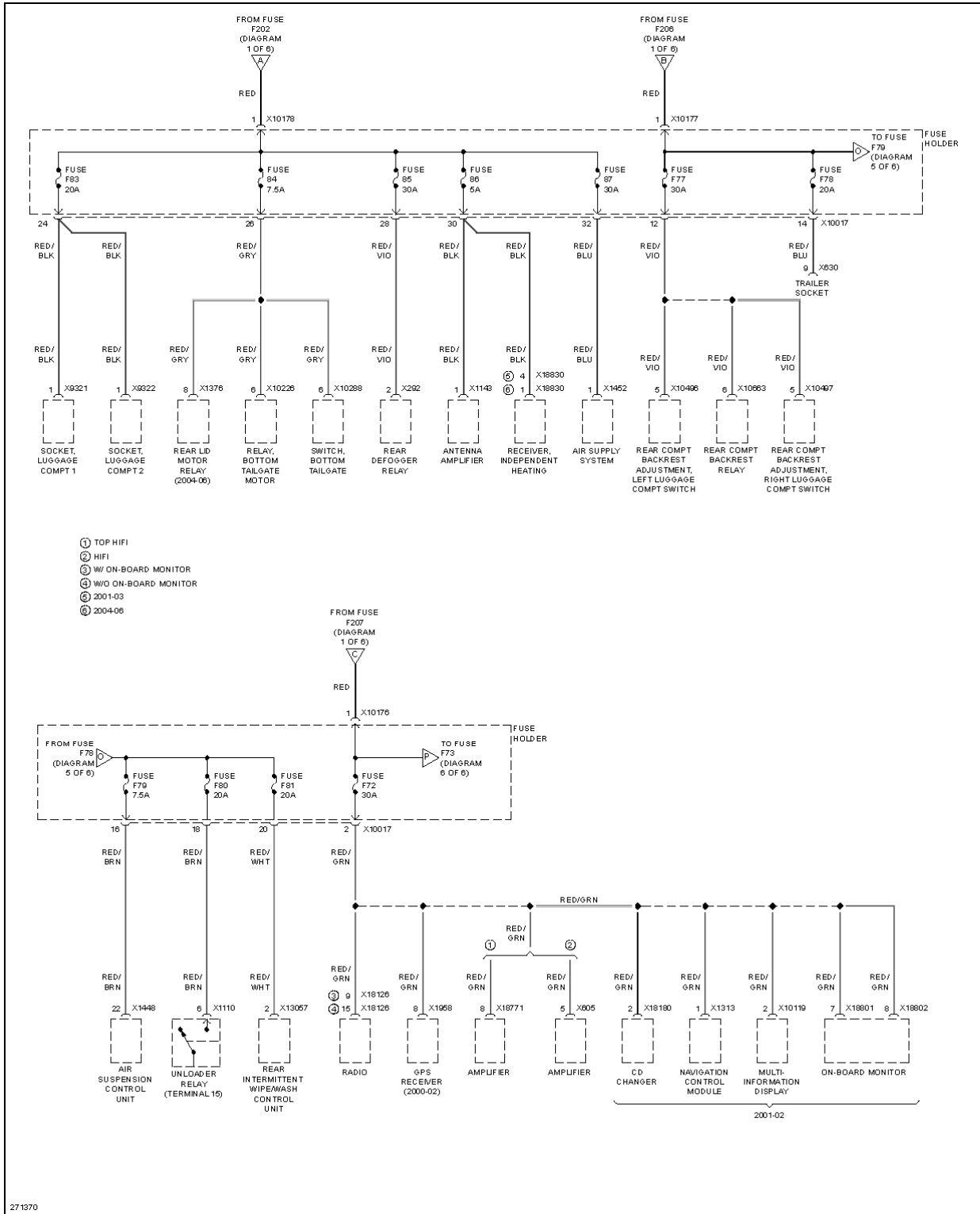

Fig. 81: 3.0L, Power Distribution Circuit (5 of 6)

2004 BMW X5 30i

2004 SYSTEM WIRING DIAGRAMS BMW - X5

Fig. 82: 3.0L, Power Distribution Circuit (6 of 6)

4.4L

2004 BMW X5 30i

2004 SYSTEM WIRING DIAGRAMS BMW - X5

Fig. 83: 4.4L, Power Distribution Circuit (1 of 6)

2004 BMW X5 30i

2004 SYSTEM WIRING DIAGRAMS BMW - X5

Fig. 84: 4.4L, Power Distribution Circuit (2 of 6)

2004 BMW X5 30i

2004 SYSTEM WIRING DIAGRAMS BMW - X5

Fig. 85: 4.4L, Power Distribution Circuit (3 of 6)

2004 BMW X5 30i

2004 SYSTEM WIRING DIAGRAMS BMW - X5

Fig. 86: 4.4L, Power Distribution Circuit (4 of 6)

2004 BMW X5 30i

2004 SYSTEM WIRING DIAGRAMS BMW - X5

Fig. 87: 4.4L, Power Distribution Circuit (5 of 6)

2004 BMW X5 30i

2004 SYSTEM WIRING DIAGRAMS BMW - X5

Fig. 88: 4.4L, Power Distribution Circuit (6 of 6)

4.8L

2004 BMW X5 30i

2004 SYSTEM WIRING DIAGRAMS BMW - X5

Fig. 89: 4.8L, Power Distribution Circuit (1 of 6)

2004 BMW X5 30i

2004 SYSTEM WIRING DIAGRAMS BMW - X5

Fig. 90: 4.8L, Power Distribution Circuit (2 of 6)

2004 BMW X5 30i

2004 SYSTEM WIRING DIAGRAMS BMW - X5

Fig. 91: 4.8L, Power Distribution Circuit (3 of 6)

2004 BMW X5 30i

2004 SYSTEM WIRING DIAGRAMS BMW - X5

Fig. 92: 4.8L, Power Distribution Circuit (4 of 6)

2004 BMW X5 30i

2004 SYSTEM WIRING DIAGRAMS BMW - X5

Fig. 93: 4.8L, Power Distribution Circuit (5 of 6)

2004 BMW X5 30i

2004 SYSTEM WIRING DIAGRAMS BMW - X5

Fig. 94: 4.8L, Power Distribution Circuit (6 of 6)

POWER DOOR LOCKS

2004 BMW X5 30i

2004 SYSTEM WIRING DIAGRAMS BMW - X5

Fig. 95: Power Door Locks Circuit (1 of 3)

2004 BMW X5 30i

2004 SYSTEM WIRING DIAGRAMS BMW - X5

Fig. 96: Power Door Locks Circuit (2 of 3)

2004 BMW X5 30i

2004 SYSTEM WIRING DIAGRAMS BMW - X5

Fig. 97: Power Door Locks Circuit (3 of 3)

POWER MIRRORS

2004 BMW X5 30i

2004 SYSTEM WIRING DIAGRAMS BMW - X5

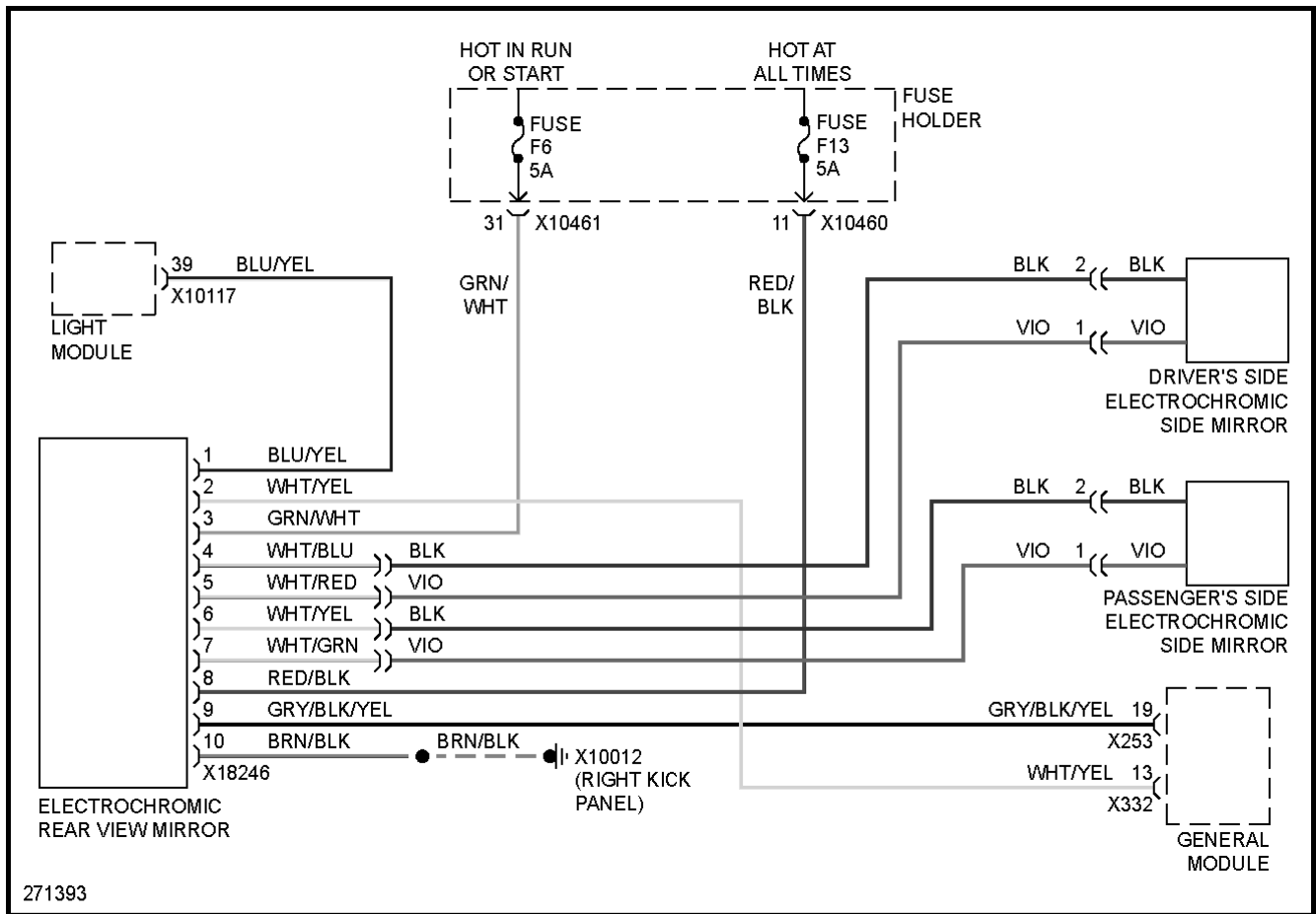

Fig. 98: Electrochromic Mirror Circuit

2004 BMW X5 30i

2004 SYSTEM WIRING DIAGRAMS BMW - X5

Fig. 99: Power Mirrors Circuit

POWER SEATS

2004 BMW X5 30i

2004 SYSTEM WIRING DIAGRAMS BMW - X5

Fig. 100: Driver's Lumbar Circuit

2004 BMW X5 30i

2004 SYSTEM WIRING DIAGRAMS BMW - X5

Fig. 101: Front Heated Seats Circuit

2004 BMW X5 30i

2004 SYSTEM WIRING DIAGRAMS BMW - X5

Fig. 102: Heated Steering Wheel Circuit

2004 BMW X5 30i

2004 SYSTEM WIRING DIAGRAMS BMW - X5

Fig. 103: Passenger Power Seat Circuit

2004 BMW X5 30i

2004 SYSTEM WIRING DIAGRAMS BMW - X5

Fig. 104: Passenger's Lumbar Circuit

2004 BMW X5 30i

2004 SYSTEM WIRING DIAGRAMS BMW - X5

Fig. 105: Rear Heated Seats Circuit

2004 BMW X5 30i

2004 SYSTEM WIRING DIAGRAMS BMW - X5

Fig. 106: Rear Power Seat Circuit

POWER TOP/SUNROOF

2004 BMW X5 30i

2004 SYSTEM WIRING DIAGRAMS BMW - X5

Fig. 107: Panoramic Roof Circuit

2004 BMW X5 30i

2004 SYSTEM WIRING DIAGRAMS BMW - X5

Fig. 108: Sunroof Circuit

POWER WINDOWS

2004 BMW X5 30i

2004 SYSTEM WIRING DIAGRAMS BMW - X5

Fig. 109: Power Windows Circuit (1 of 3)

2004 BMW X5 30i

2004 SYSTEM WIRING DIAGRAMS BMW - X5

Fig. 110: Power Windows Circuit (2 of 3)

2004 BMW X5 30i

2004 SYSTEM WIRING DIAGRAMS BMW - X5

Fig. 111: Power Windows Circuit (3 of 3)

RADIO

2004 BMW X5 30i

2004 SYSTEM WIRING DIAGRAMS BMW - X5

Fig. 112: Premium Radio Circuit, W/ HIFI Radio (1 of 3)

2004 BMW X5 30i

2004 SYSTEM WIRING DIAGRAMS BMW - X5

Fig. 113: Premium Radio Circuit, W/ HIFI Radio (2 of 3)

2004 BMW X5 30i

2004 SYSTEM WIRING DIAGRAMS BMW - X5

Fig. 114: Premium Radio Circuit, W/ HIFI Radio (3 of 3)

2004 BMW X5 30i

2004 SYSTEM WIRING DIAGRAMS BMW - X5

Fig. 115: Premium Radio Circuit, W/ Top HIFI Radio (1 of 3)

2004 BMW X5 30i

2004 SYSTEM WIRING DIAGRAMS BMW - X5

Fig. 116: Premium Radio Circuit, W/ Top HIFI Radio (2 of 3)

2004 BMW X5 30i

2004 SYSTEM WIRING DIAGRAMS BMW - X5

Fig. 117: Premium Radio Circuit, W/ Top HIFI Radio (3 of 3)

2004 BMW X5 30i

2004 SYSTEM WIRING DIAGRAMS BMW - X5

Fig. 118: Radio Circuit (1 of 2)

2004 BMW X5 30i

2004 SYSTEM WIRING DIAGRAMS BMW - X5

Fig. 119: Radio Circuit (2 of 2)

SHIFT INTERLOCK

3.0L

2004 BMW X5 30i

2004 SYSTEM WIRING DIAGRAMS BMW - X5

Fig. 120: 3.0L, Shift Interlock Circuit

4.4L

2004 BMW X5 30i

2004 SYSTEM WIRING DIAGRAMS BMW - X5

Fig. 121: 4.4L, Shift Interlock Circuit

4.8L

2004 BMW X5 30i

2004 SYSTEM WIRING DIAGRAMS BMW - X5

Fig. 122: 4.8L, Shift Interlock Circuit

STARTING/CHARGING

3.0L

2004 BMW X5 30i

2004 SYSTEM WIRING DIAGRAMS BMW - X5

Fig. 123: 3.0L, Charging Circuit

2004 BMW X5 30i

2004 SYSTEM WIRING DIAGRAMS BMW - X5

Fig. 124: 3.0L, Starting Circuit

4.4L

2004 BMW X5 30i

2004 SYSTEM WIRING DIAGRAMS BMW - X5

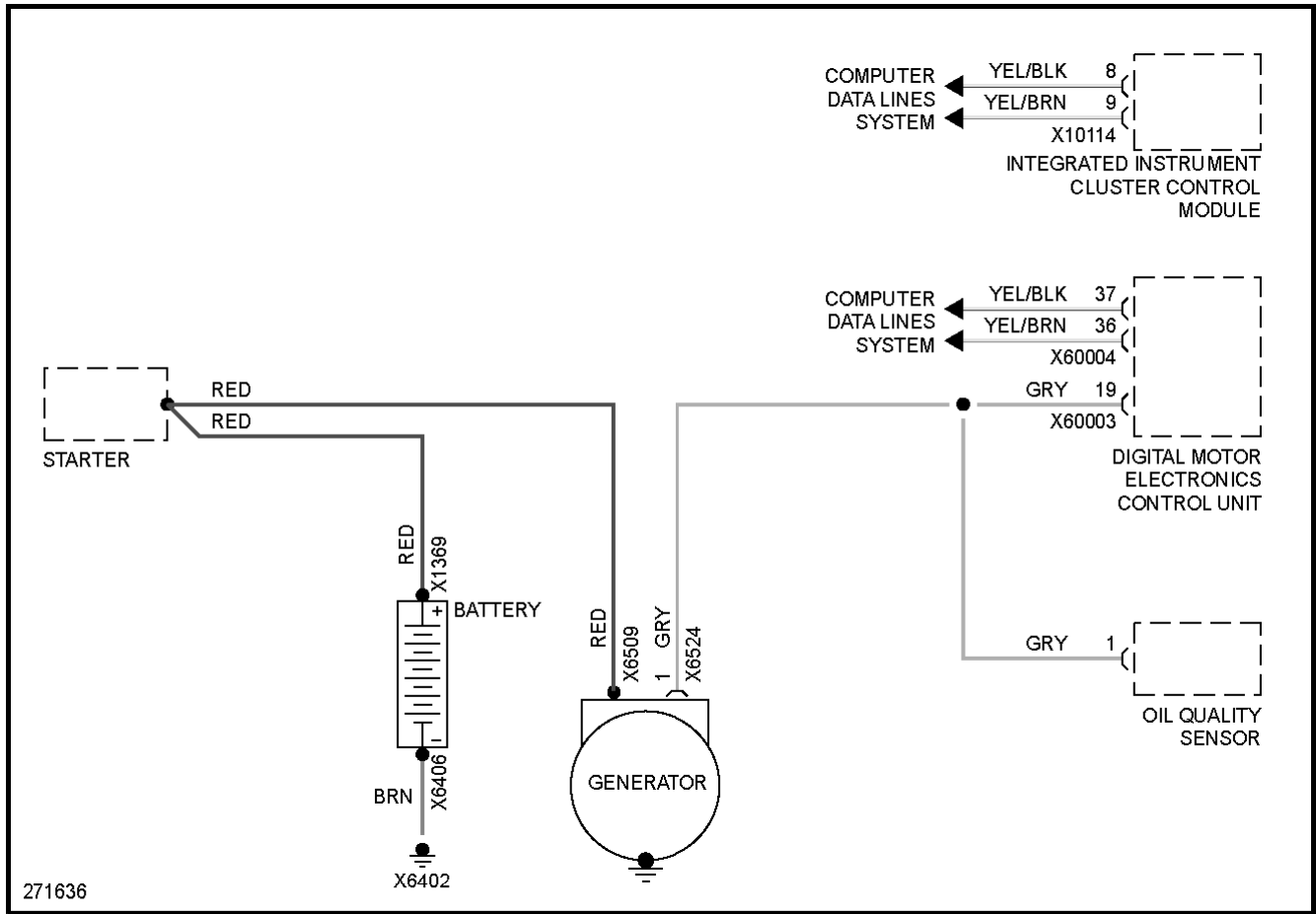

Fig. 125: 4.4L, Charging Circuit

2004 BMW X5 30i

2004 SYSTEM WIRING DIAGRAMS BMW - X5

Fig. 126: 4.4L, Starting Circuit

4.8L

2004 BMW X5 30i

2004 SYSTEM WIRING DIAGRAMS BMW - X5

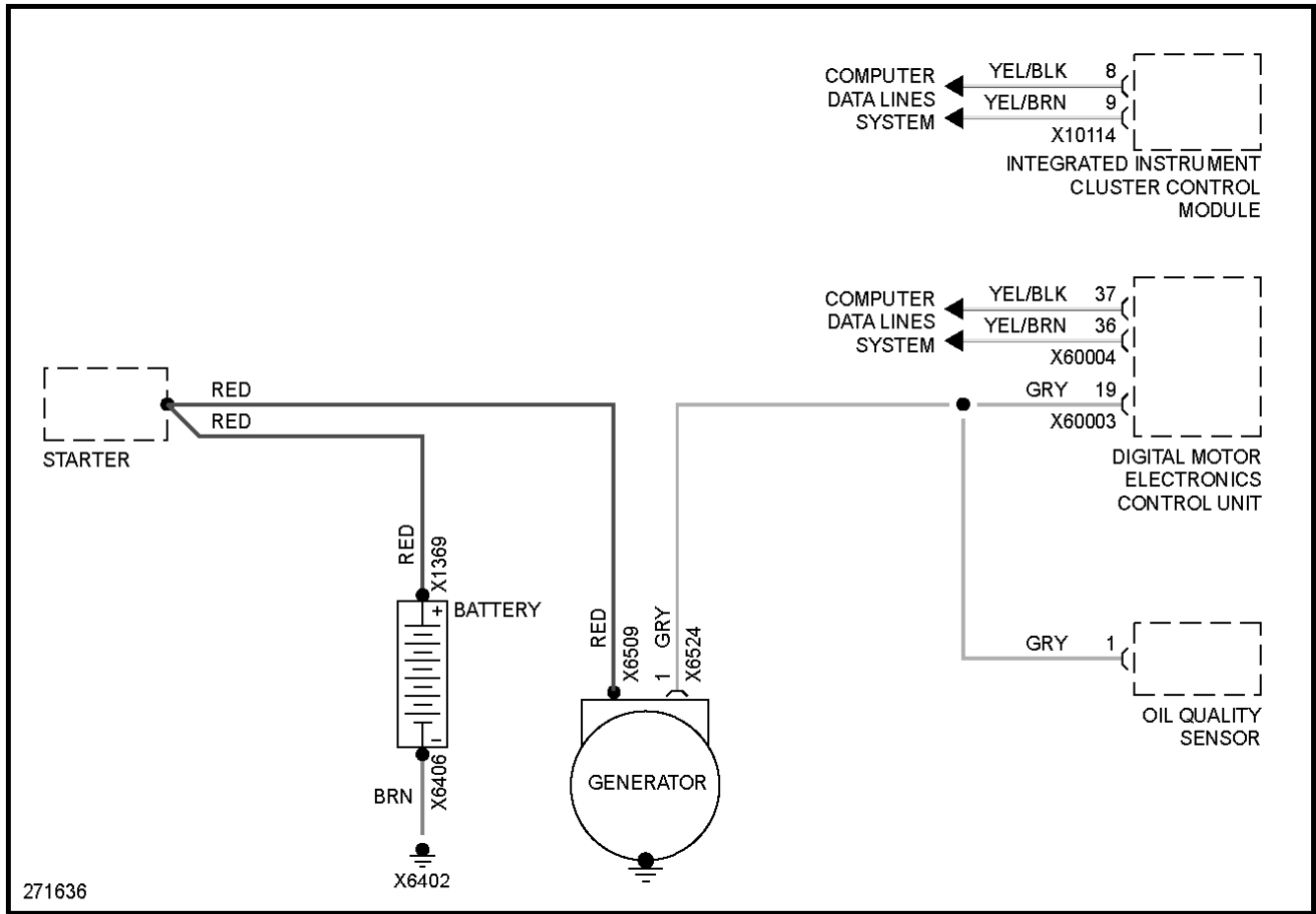

Fig. 127: 4.8L, Charging Circuit

2004 BMW X5 30i

2004 SYSTEM WIRING DIAGRAMS BMW - X5

Fig. 128: 4.8L, Starting Circuit

SUPPLEMENTAL RESTRAINTS

2004 BMW X5 30i

2004 SYSTEM WIRING DIAGRAMS BMW - X5

Fig. 129: Supplemental Restraints Circuit

TRANSMISSION

2004 BMW X5 30i

2004 SYSTEM WIRING DIAGRAMS BMW - X5

Fig. 130: AWD Circuit

3.0L

2004 BMW X5 30i

2004 SYSTEM WIRING DIAGRAMS BMW - X5

Fig. 131: 3.0L, A/T Circuit (1 of 2)

2004 BMW X5 30i

2004 SYSTEM WIRING DIAGRAMS BMW - X5

Fig. 132: 3.0L, A/T Circuit (2 of 2)

4.4L

2004 BMW X5 30i

2004 SYSTEM WIRING DIAGRAMS BMW - X5

Fig. 133: 4.4L, A/T Circuit

4.8L

2004 BMW X5 30i

2004 SYSTEM WIRING DIAGRAMS BMW - X5

Fig. 134: 4.8L, A/T Circuit

TRUNK, TAILGATE, FUEL DOOR

2004 BMW X5 30i

2004 SYSTEM WIRING DIAGRAMS BMW - X5

Fig. 135: Trunk & Fuel Door Release Circuit

WARNING SYSTEMS

2004 BMW X5 30i

2004 SYSTEM WIRING DIAGRAMS BMW - X5

Fig. 136: Tire Pressure Monitoring Circuit

WIPER/WASHER

2004 BMW X5 30i

2004 SYSTEM WIRING DIAGRAMS BMW - X5

Fig. 137: Wiper/Washer Circuit (1 of 3)

2004 BMW X5 30i

2004 SYSTEM WIRING DIAGRAMS BMW - X5

Fig. 138: Wiper/Washer Circuit (2 of 3)

2004 BMW X5 30i

2004 SYSTEM WIRING DIAGRAMS BMW - X5

Fig. 139: Wiper/Washer Circuit (3 of 3)